

<b>SYSTEMS</b>	<b>680</b>
EDGE TYPE	685
<b>INSTALLATION</b>	<b>686</b>
GENERAL REQUIREMENTS	686
FRAMING	687
ACCESS PANEL	697
LAYOUT	698
FIXING	700
FINISHING	702
<b>CONSTRUCTION DETAILS</b>	<b>703</b>

## 6.8 Createx Perforated Plasterboard

**createx** with CAPT'AIR® technology brings a breath of fresh air to wall and acoustic ceiling linings. Delivering excellent acoustic performance, stunning aesthetics and CAPT'AIR® air cleaning properties, **createx** is the smart choice for all commercial applications.

Manufactured with high quality, ultra-sharp perforations in a variety of continuous perforated patterns for a seamless finish, **createx** with CAPT'AIR® technology meets the high level of acoustic performance required for commercial public areas such as offices, shopping centres, airports, schools, hospitals, conference halls, lecture theatres and libraries.

**createx** with CAPT'AIR® technology incorporates urea polymer manufacturing process which reacts with formaldehyde creating a non-harmful compound that is absorbed by the plasterboard. This results in a safer environment for any space where **createx** is installed.



**Round R8/18**

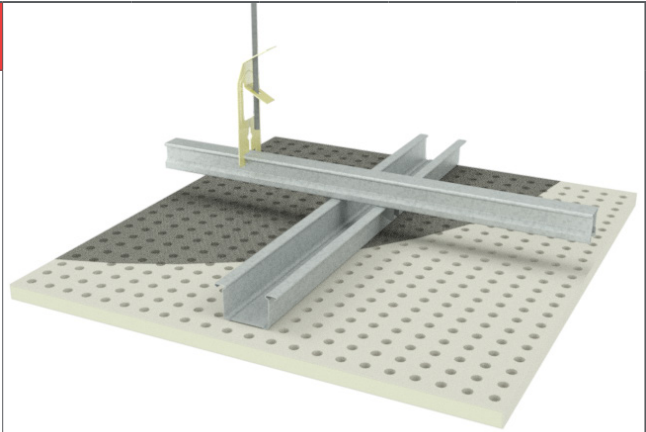
8mm diameter circle perforations with dark backing fleece

**Open Area:** 14.3 %

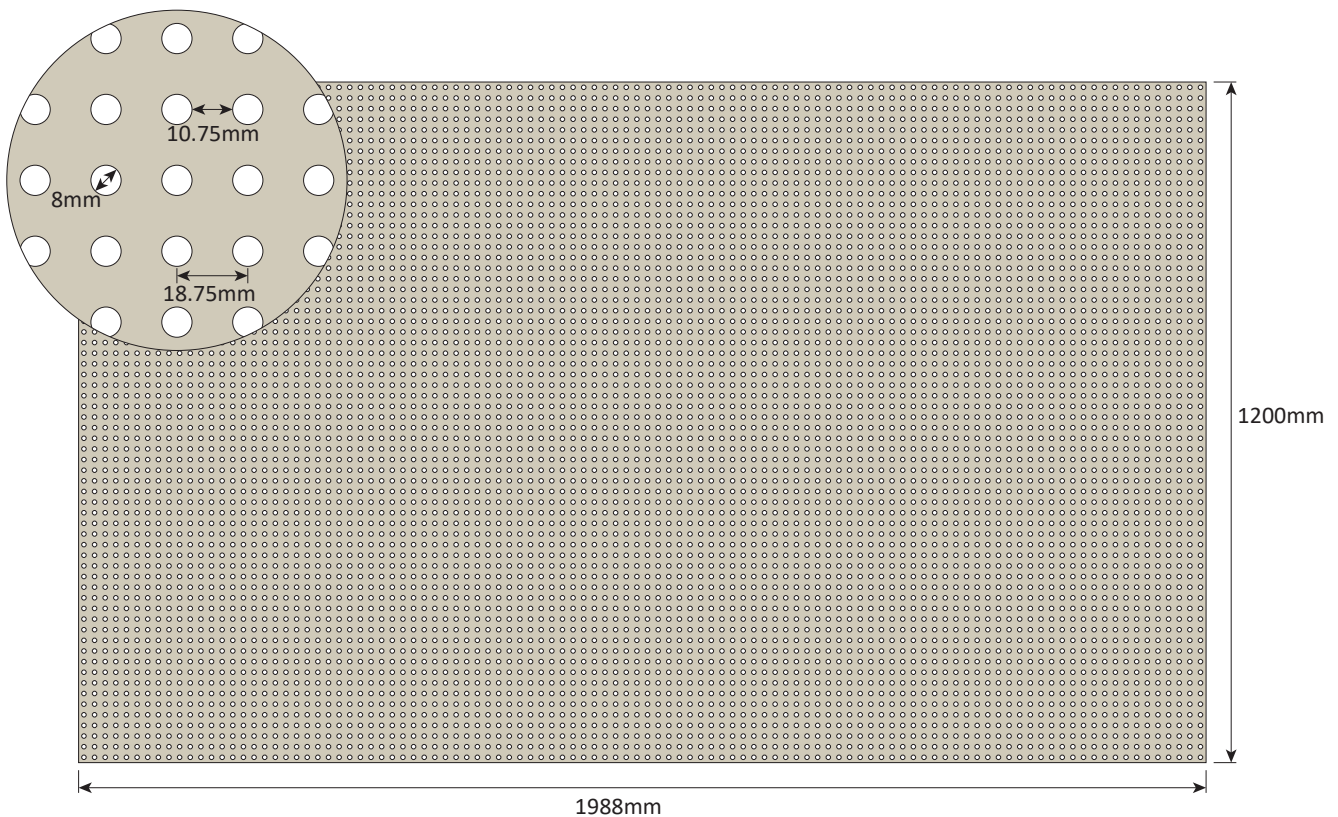
**Furring Channel Centres:** 400mm maximum

**Sheet Dimensions:** 1200 x 1988 x 12.5mm

**Weight:** 10 kg/m<sup>2</sup> (approximate)



	Ceiling Cavity (mm)	$\alpha_p$ - Frequency (Hz)						$\alpha_w$	NRC
		125	250	500	1000	2000	4000		
Pink® Partition 50mm 14kg/m <sup>3</sup> R1.3	37	0.35	0.85	1.0	0.9	0.65	0.6	<b>0.7</b>	<b>0.85</b>
	187	0.55	0.95	0.85	0.85	0.65	0.6	<b>0.7</b>	<b>0.85</b>
Pink® Partition 75mm 14kg/m <sup>3</sup> R1.9	187	0.55	0.8	0.8	0.75	0.7	0.65	<b>0.7</b>	<b>0.75</b>
No Insulation	187	0.45	0.7	0.8	0.7	0.65	0.6	<b>0.7</b>	<b>0.7</b>
Pink® Partition 75mm 14kg/m <sup>3</sup> R1.9	587	0.65	0.7	0.8	0.7	0.6	0.65	<b>0.7</b>	<b>0.7</b>





**Round R12/25**

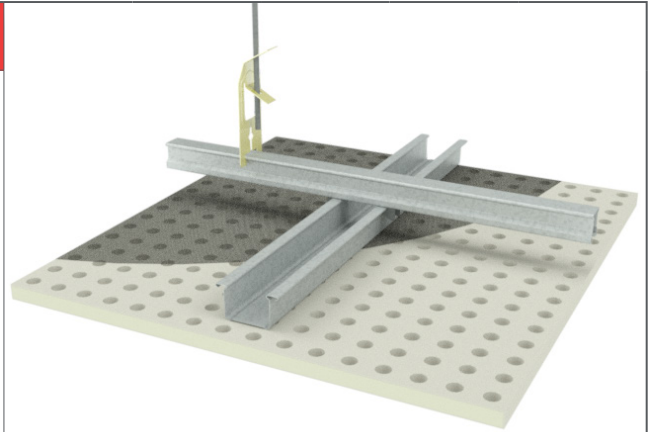
12mm diameter circle perforations with dark backing fleece

**Open Area:** 18.2 %

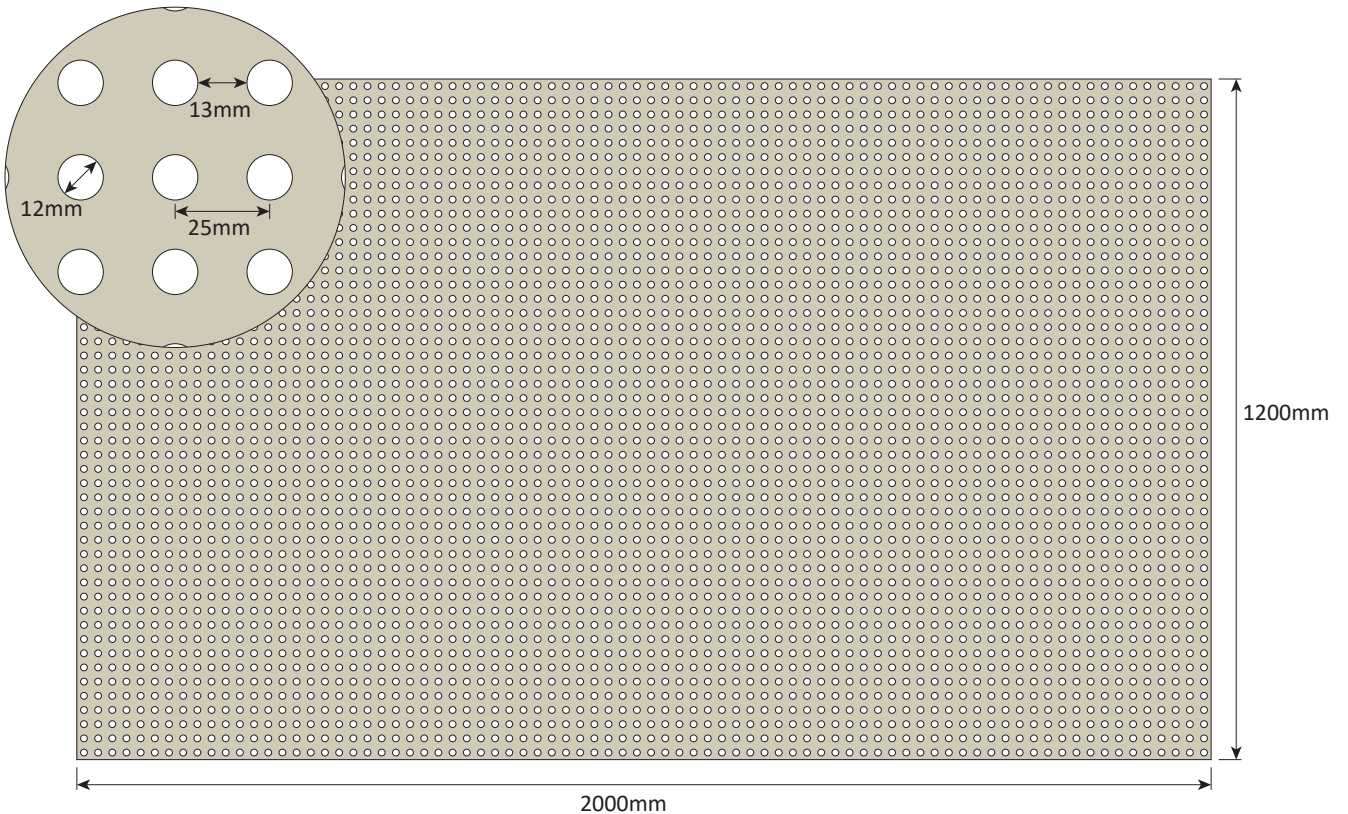
**Furring Channel Centres:** 400mm maximum

**Sheet Dimensions:** 1200 x 2000 x 12.5mm

**Weight:** 10 kg/m<sup>2</sup> (approximate)



	Ceiling Cavity (mm)	$\alpha_p$ - Frequency (Hz)						$\alpha_w$	NRC
		125	250	500	1000	2000	4000		
Pink® Partition 50mm 14kg/m <sup>3</sup> R1.3	37	0.35	0.75	0.95	0.9	0.75	0.65	<b>0.8</b>	<b>0.85</b>
Pink® Partition 75mm 14kg/m <sup>3</sup> R1.9	187	0.6	0.8	0.85	0.8	0.8	0.75	<b>0.75</b>	<b>0.8</b>
No Insulation	187	0.45	0.75	0.9	0.7	0.7	0.55	<b>0.7</b>	<b>0.75</b>





**Cube C12/25**

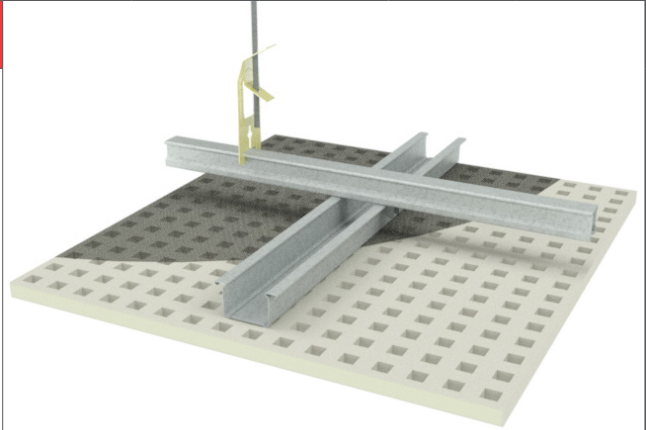
12mm square perforations with dark backing fleece

**Open Area:** 23.1 %

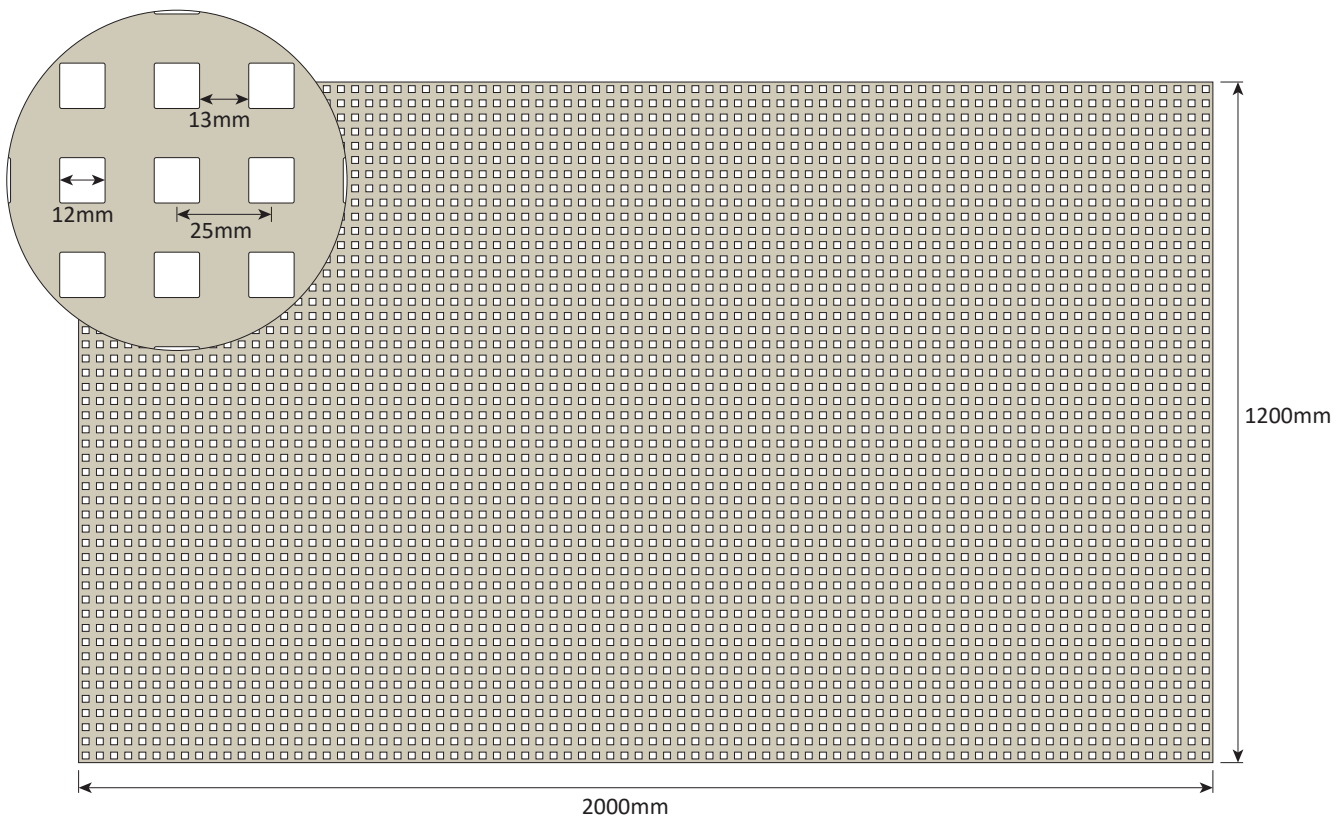
**Furring Channel Centres:** 400mm maximum

**Sheet Dimensions:** 1200 x 2000 x 12.5mm

**Weight:** 10 kg/m<sup>2</sup> (approximate)



	Ceiling Cavity (mm)	$\alpha_p$ - Frequency (Hz)						$\alpha_w$	NRC
		125	250	500	1000	2000	4000		
Pink® Partition 50mm 14kg/m <sup>3</sup> R1.3	37	0.25	0.7	0.85	0.85	0.75	0.75	<b>0.85</b>	<b>0.8</b>
No Insulation	187	0.45	0.8	0.9	0.75	0.7	0.65	<b>0.75</b>	<b>0.8</b>
Pink® Partition 75mm 14kg/m <sup>3</sup> R1.9	187	0.6	0.9	0.95	0.9	0.85	0.8	<b>0.9</b>	<b>0.9</b>
Pink® Partition 75mm 14kg/m <sup>3</sup> R1.9	587	0.75	0.8	0.9	0.85	0.75	0.8	<b>0.85</b>	<b>0.85</b>





**Dynamic D8-12**

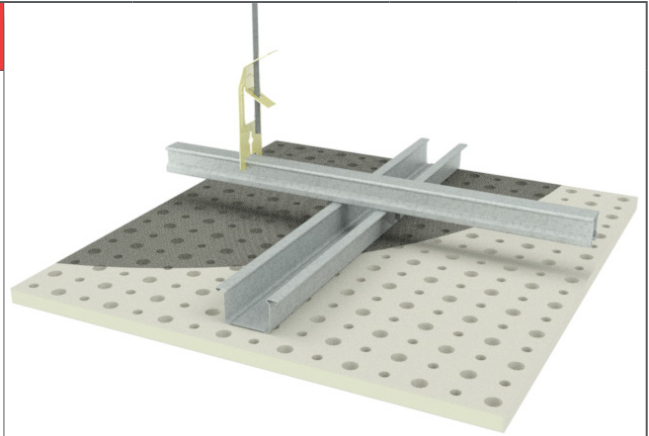
8mm and 12mm diameter circle perforations with dark backing fleece

**Open Area:** 13.1 %

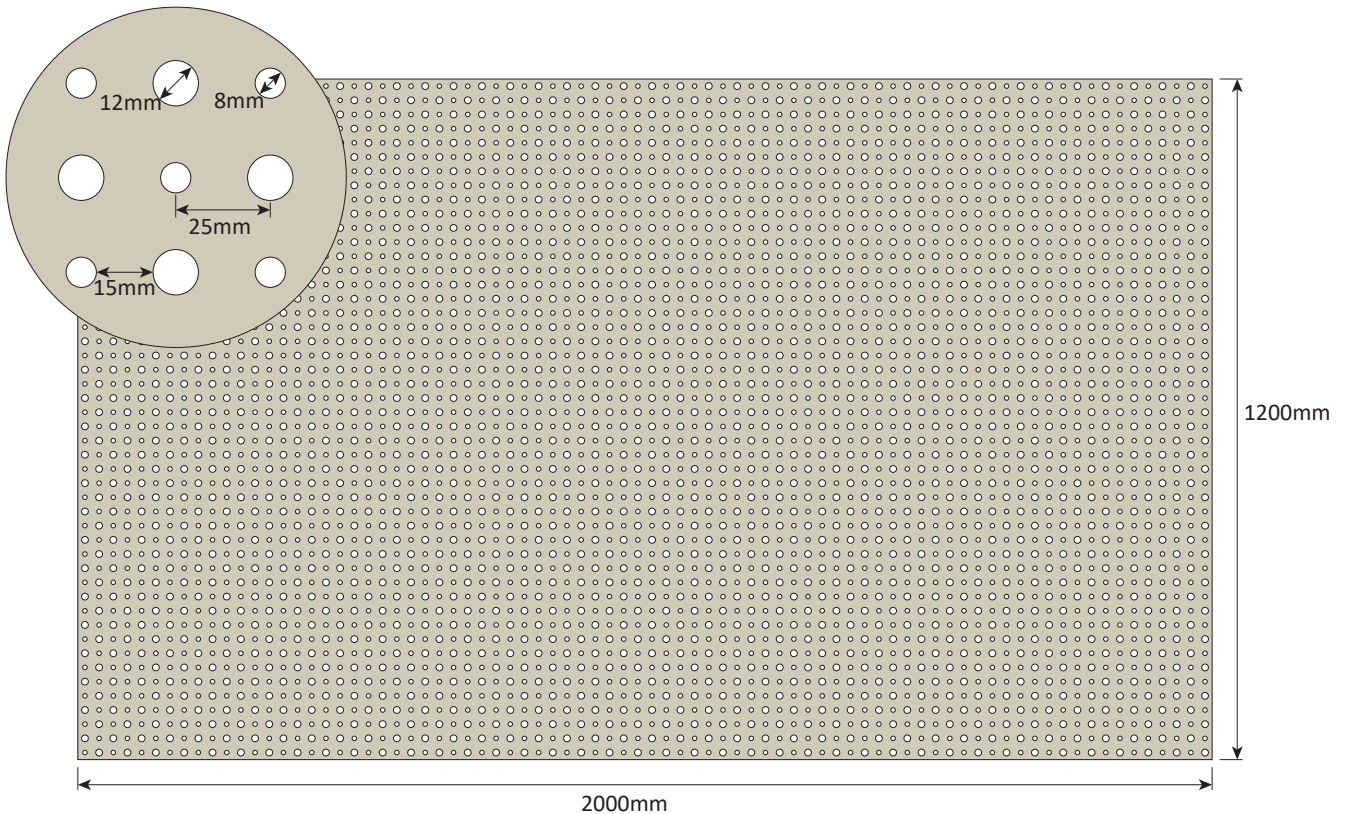
**Furring Channel Centres:** 400mm maximum

**Sheet Dimensions:** 1200 x 2000 x 12.5mm

**Weight:** 10 kg/m<sup>2</sup> (approximate)



	Ceiling Cavity (mm)	$\alpha_p$ - Frequency (Hz)						$\alpha_w$	NRC
		125	250	500	1000	2000	4000		
No Insulation	187	0.25	0.65	0.6	0.35	0.3	0.35	<b>0.35</b>	<b>0.5</b>
Pink® Partition 75mm 14kg/m <sup>3</sup> R1.9	187	0.55	1.0	0.9	0.7	0.5	0.45	<b>0.55</b>	<b>0.8</b>
Pink® Partition 75mm 14kg/m <sup>3</sup> R1.9	587	0.6	0.7	0.75	0.7	0.6	0.6	<b>0.7</b>	<b>0.7</b>





**Space S8-15-20**

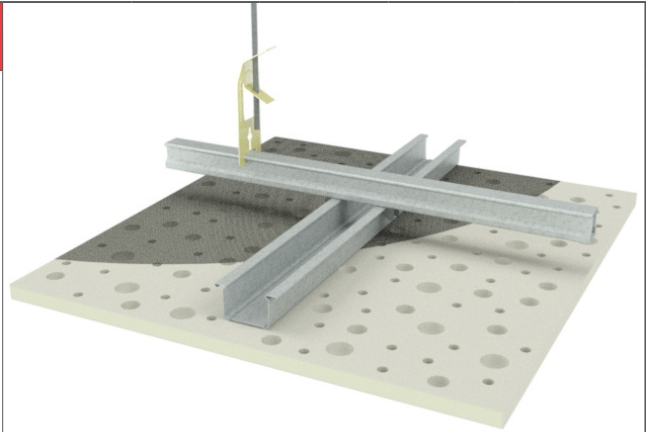
8mm, 15mm and 20mm diameter circle perforations with dark backing fleece

**Open Area:** 10.2 %

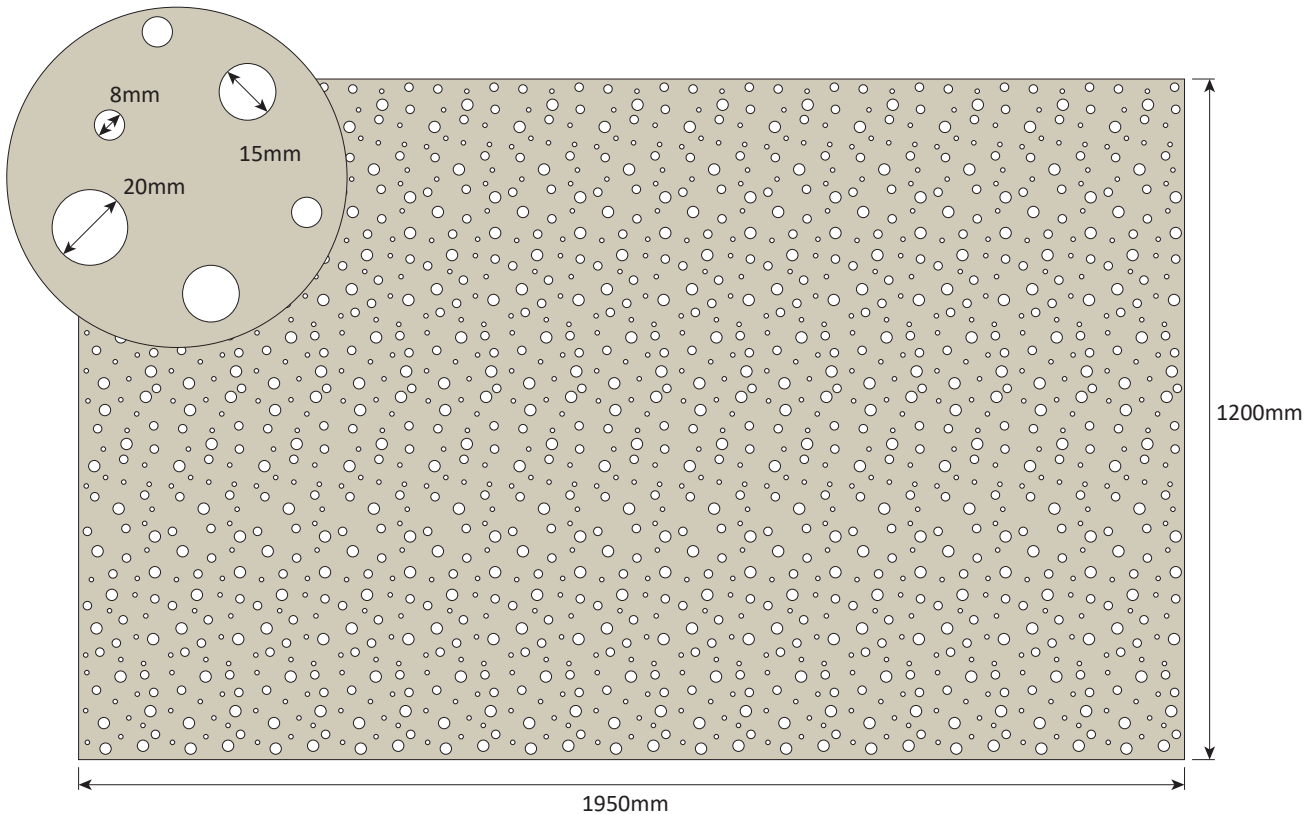
**Furring Channel Centres:** 400mm maximum

**Sheet Dimensions:** 1200 x 1950 x 12.5mm

**Weight:** 10 kg/m<sup>2</sup> (approximate)



	Ceiling Cavity (mm)	$\alpha_p$ - Frequency (Hz)						$\alpha_w$	NRC
		125	250	500	1000	2000	4000		
Pink® Partition 50mm 14kg/m <sup>3</sup> R1.3	37	0.4	0.7	0.65	0.65	0.5	0.5	<b>0.6</b>	<b>0.65</b>
No Insulation	187	0.45	0.65	0.7	0.6	0.45	0.4	<b>0.5</b>	<b>0.6</b>
Pink® Partition 50mm 14kg/m <sup>3</sup> R1.3	187	0.45	0.6	0.65	0.65	0.5	0.5	<b>0.6</b>	<b>0.6</b>
Pink® Partition 75mm 14kg/m <sup>3</sup> R1.9	187	0.5	0.65	0.65	0.65	0.5	0.5	<b>0.6</b>	<b>0.6</b>
Pink® Partition 75mm 14kg/m <sup>3</sup> R1.9	587	0.6	0.6	0.7	0.65	0.45	0.45	<b>0.55</b>	<b>0.6</b>



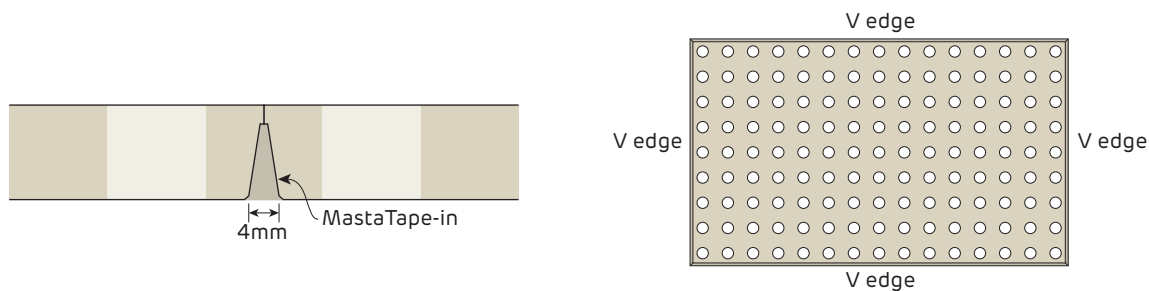
## Edge Type

### V Edge

All **createx** perforation patterns come with a V edge profile.

The V edge profile easily facilitates precise alignment of the perforated boards, ensuring that the boards are straight and the continuous perforation patterns align perfectly.

The V edge is used when a jointless appearance is required. Joints are tapeless and virtually invisible when filled with **mastatape-in** jointing compound followed by **mastalite**, **mastaglide**, or **mastaline** to finish the joint ready for painting.



**FIGURE 1 V Edge**  
Section

### Creutex Jointing Compound

Name	Size	Type	Application
			Creutex Joints
<b>mastatape-in</b>	20 kg bucket	Premix	✓





## General Requirements

Install control joints in plasterboard ceilings:

- > At 10m maximum intervals
- > At all control joints in the structure
- > At any change in the substrate
- > At the junction of a larger room and passageway.

Separate **createx** ceilings from other building elements, such as walls and columns by creating control joints that allow for movement, e.g. utilising a shadow line profile or tear away bead.

Do not rigidly fix **createx** to the perimeter.

All ceilings in this section are non-trafficable. Do not walk on plasterboard ceilings!

Limit dead loads on **createx** ceilings to 2 kg/m<sup>2</sup>.

Attach ceiling fixtures to framing members only. Ensure the framing is designed to carry any additional load.

Cut all openings for services before jointing with **mastatape-in**.

Locate ceiling services between framing to avoid cutting of top cross rails or furring channels. If furring channels are cut then provide additional support with top cross rails and hangers. Refer to Figures 15 and 16.



> **createx** must have an air cavity behind it for it to perform as a sound absorber.

> **createx** installations in close proximity to metal roofs (i.e. raked ceiling or with small ceiling cavities) require smaller control joint intervals or joints left unfilled as they are exposed to larger rates of thermal expansion and contraction of the roof and/or ceiling framing otherwise cracking of the ceiling and joint peaking is expected.

> Excessive vibration of the ceiling (by installing ceiling services, etc) is known to cause jointing cracking and joint peaking.

> Locate ceiling services so they do not cut through ceiling framing members, otherwise some degradation of the ceiling can be expected.



Use the Siniat Reverberation time calculator to assist in determining how much of the ceiling and or wall area should be covered. Alternatively involve an acoustic consultant, especially for very high ceilings and unusually shaped rooms such as those with domed or sloping ceilings.

### Siniat Reverberation Time Calculator



Use Siniat's Reverberation Time Calculator by clicking on the link or by using your phone's camera on the QR code.





## Framing

Framing members as per framing tables or structural design up to 400mm maximum. Also refer to Section 5.1 for more information on ceiling framing.
For a specific project, determine the relevant wind pressure load on an internal ceiling from Section 2.3, or the QR link below. Wind pressure loads must be considered for internal ceilings to comply with AS/NZS 1170.2 <i>Wind Actions</i> and AS/NZS 2785 <i>Suspended Ceilings - Design and Installation</i> .
Contact Siniat or a structural engineer to check ceiling for earthquake actions. Specific project information is required.
Stagger joins in adjacent Top Cross Rails and Furring Channels by 1200mm minimum.
Install additional framing members around openings.
Downstruts must be installed for Top Cross Rail suspended ceilings in all buildings except air-conditioned hospitals, offices and shopping centres that are effectively sealed where the external walls have non-opening windows. Refer to Downstrut Framing Tables.



Do not fix **createx** directly to timber joists

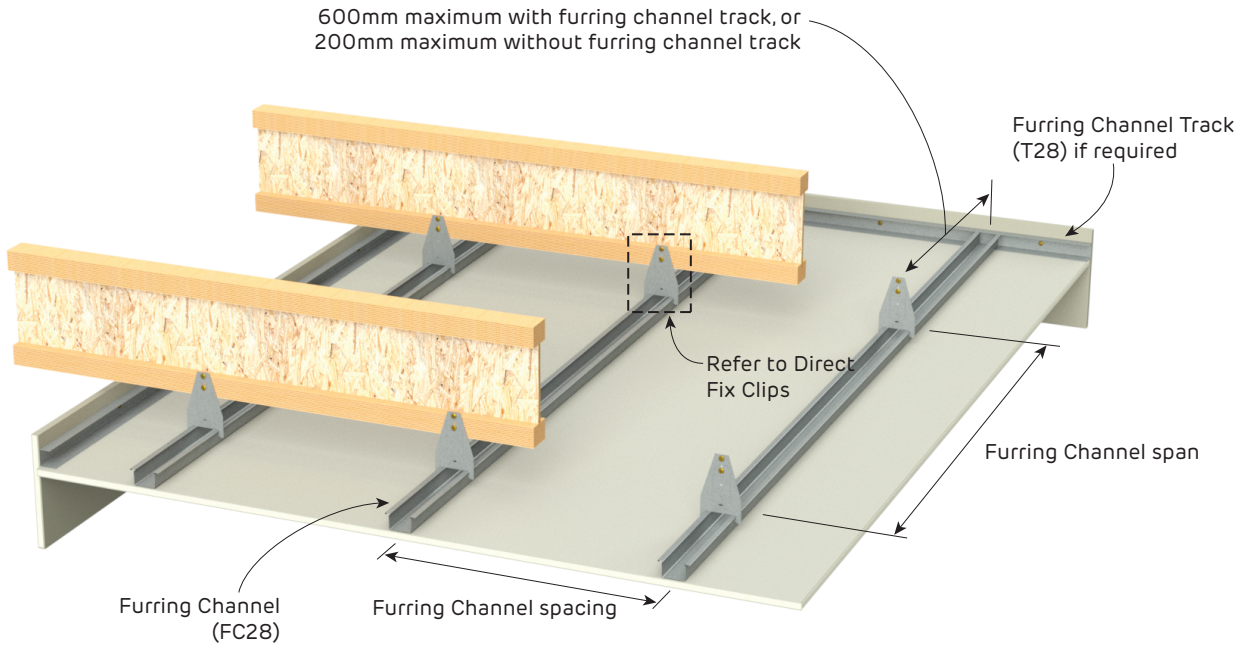
### Siniat Internal Wind Load Calculator



Refer to Section 2.3 for assistance determining the relevant internal wind pressures for a specific project. Or use the Siniat Internal Wind Load Calculator by clicking on the link or by using your phone's camera on the QR code.

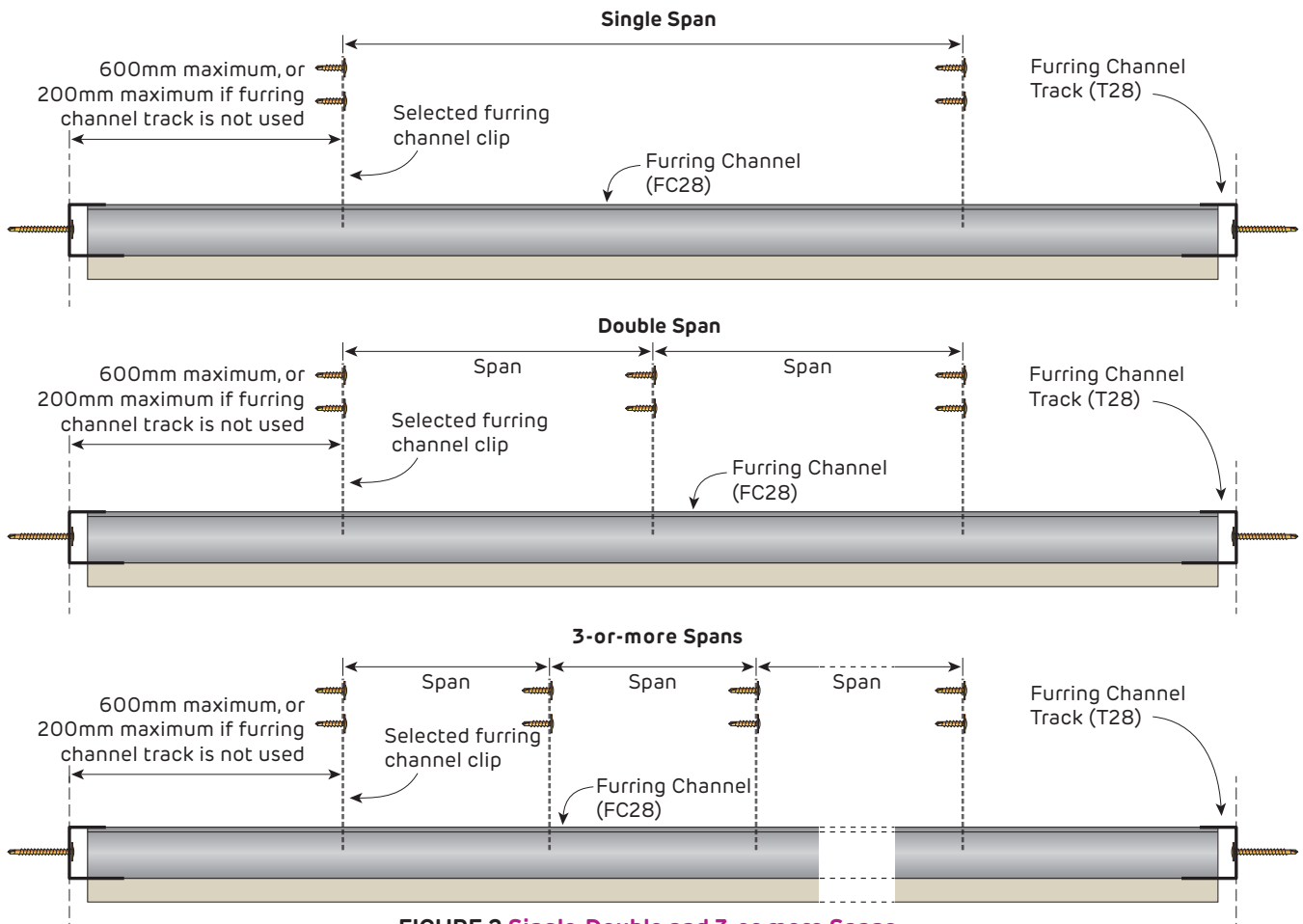


**Non-Fire Rated  
Internal Direct Fix Ceiling Frames**



**FIGURE 1 Direct Fix Furring Channel Ceiling Frame**  
Perspective

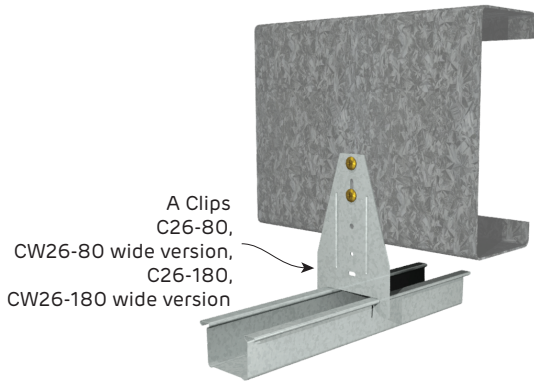
**Details for Single Span, Double Span or 3-or-More Span Ceilings**



**FIGURE 2 Single, Double and 3-or-more Spans**  
Section

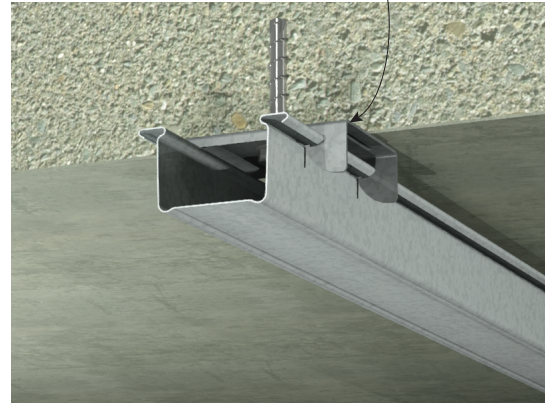


### Non-Fire Rated Typical Direct Fix Clips



**FIGURE 3** A Clip and Furring Channel  
Perspective

Furring Channel Anchor Clip  
C37-7H,  
CW37-7H wide version,  
C37-9H,  
CW37-9H wide version



**FIGURE 4** Anchor Clip and Furring Channel  
Perspective



Direct fixing clips may generate noise when fixed to materials subject to daily thermal expansion and contraction

**Table 1 28mm Furring Channel Ceiling Span Table**

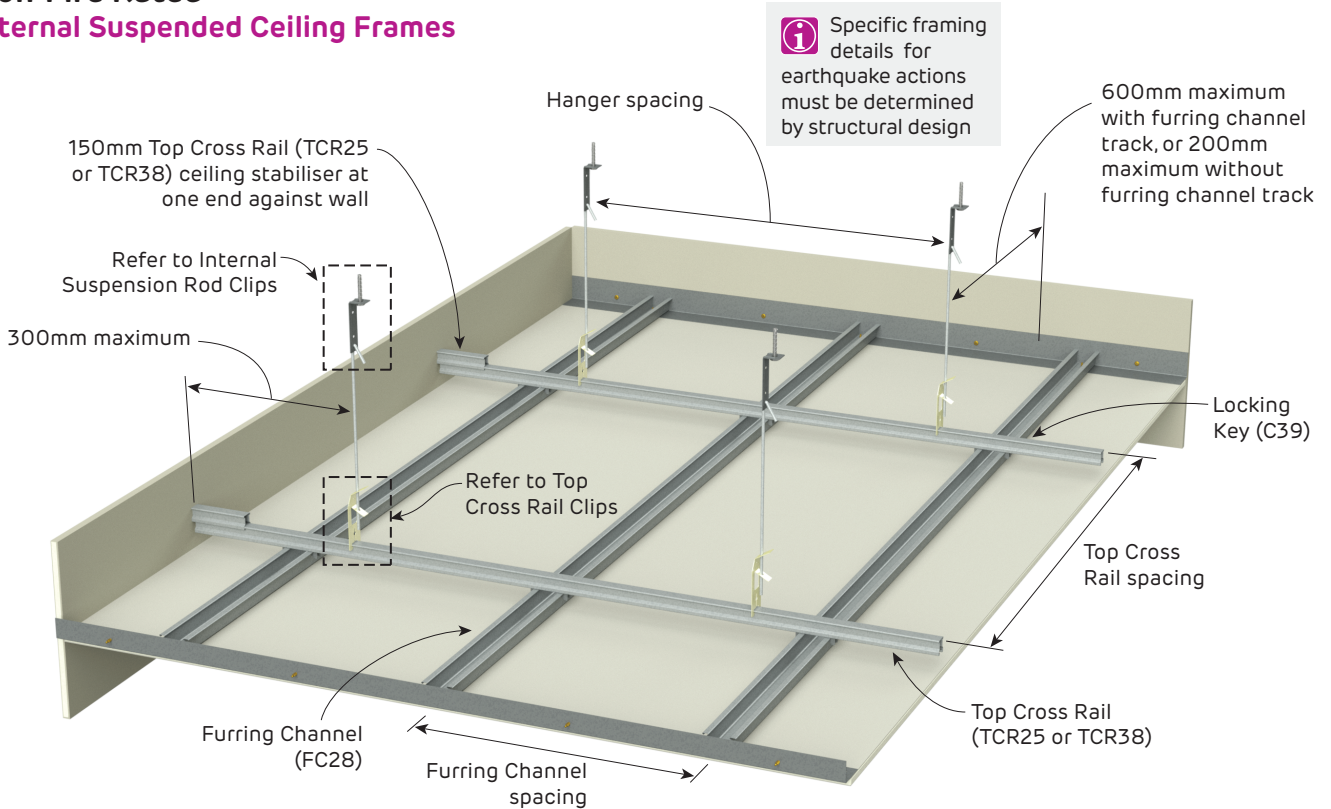
Refer to Section 2.3 for assistance determining the relevant wind pressures for a specific project.

28mm Furring Channel (AFC28) Ceiling Span Table Furring channels at 400mm maximum spacing						
Wind Region	Ultimate Wind Pressure $W_u$ (kPa)	Serviceability Wind Pressure $W_s$ (kPa)	Single Span		2 or more Spans	
			Maximum Span (mm)	Connection Demand (kN)	Maximum Span (mm)	Connection Demand (kN)
REGION A	0.39	0.25	1350	0.15	1670	0.47
	0.47	0.3	1270	0.16	1570	0.50
	0.54	0.35	1200	0.17	1490	0.53
REGION B	0.59	0.25	1350	0.20	1670	0.63
	0.71	0.3	1270	0.22	1570	0.69
	0.83	0.35	1200	0.24	1490	0.74

1. Table based upon downward (suction) and upward (uplift) pressures, intended for internal use only.
2. Table includes self weight and 2 kg/m<sup>2</sup> insulation weight with an additional 3 kg/m<sup>2</sup> service load. No further allowance for additional point loads or live loads.
3. Contact Siniat or a structural engineer to check ceiling for earthquake actions. Specific project information is required.
4. Table refers to Siniat Furring Channel of Base Metal Thickness (BMT) 0.42mm of grade G550 steel with Zincolume™ AM150 corrosion protection. Maximum production lengths available are 6.0m
5. Designed in accordance with AS/NZS 4600:2018 *Cold Formed Steel Structures* and AS/NZS 2785:2000 *Suspended Ceilings - Design and Installation*.
6. Wind pressures determined in accordance with AS/NZS 1170.2 *Wind Actions*.
7. Connections to clips must be checked with the *Clip Capacity Table* in Section 5.1.
8. Ultimate Limit State Load Case 1: 1.2G +  $W_u$  (Suction) +  $Q_{0.03kPa}$  Service Load  
Ultimate Limit State Load Case 2: 0.9G +  $W_u$  (Uplift).
9. Serviceability Limit State Load Case 1: G, with deflection limited to Span/500.  
Serviceability Limit State Load Case 2:  $W_s$ , with deflection limited to Span/360.
10. Perimeter anchors at 600mm maximum centres and 100mm maximum from track ends with minimum 0.7 kN shear capacity.
11. The nominated lateral pressures and deflection limits must be checked for suitability for a specific project.
12. For BCA Building Importance Level 4, please contact Siniat.

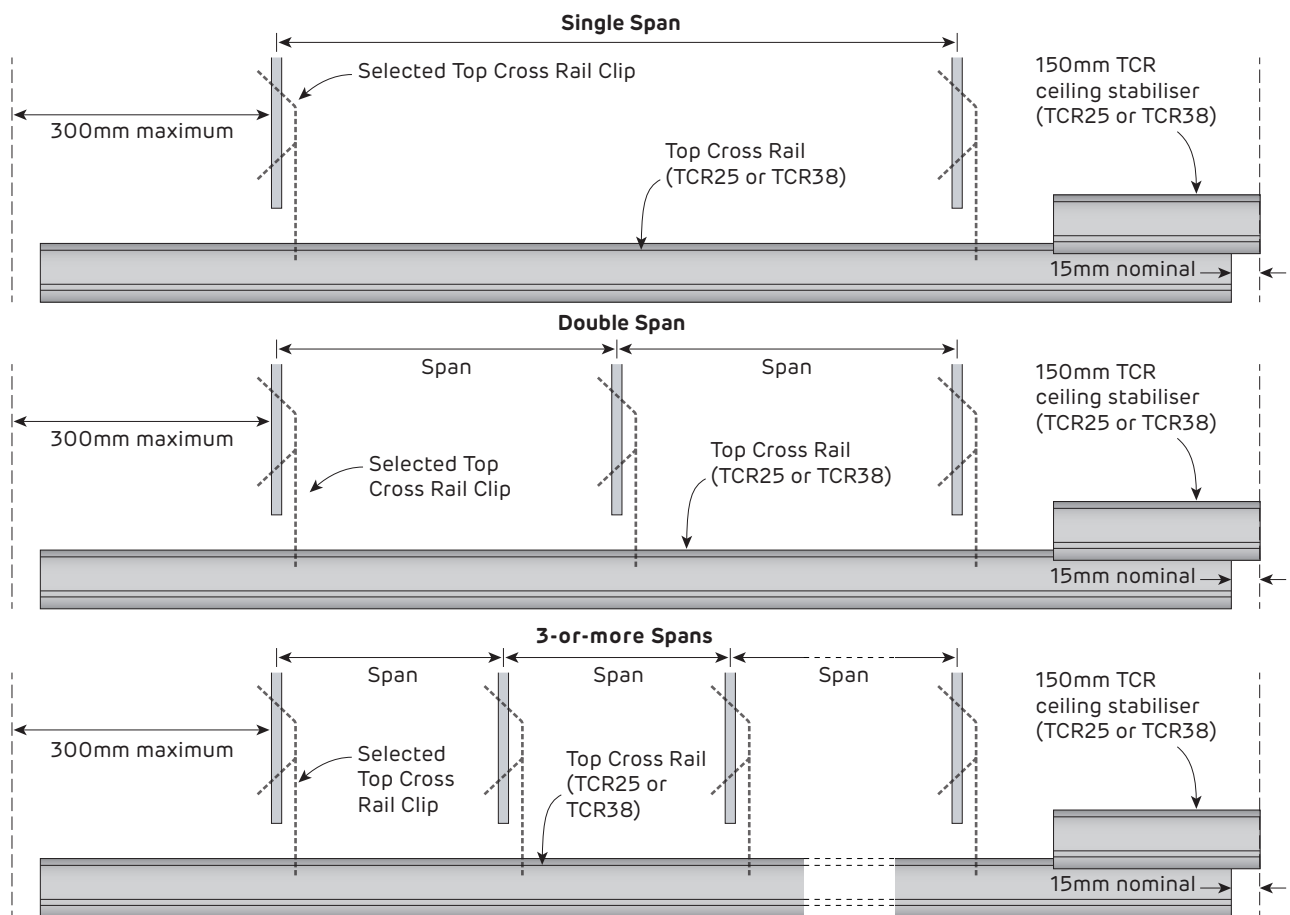


### Non-Fire Rated Internal Suspended Ceiling Frames



**FIGURE 5** Suspended Ceiling Frame  
Perspective

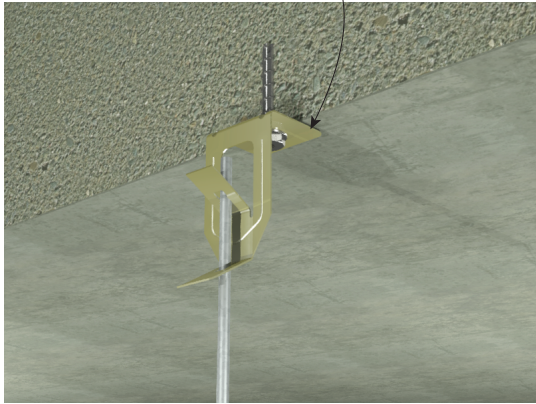
### Details for Single Span, Double Span or 3-or-More Span Ceilings



**FIGURE 6** Top Cross Rail - Single, Double and 3-or-more Spans  
Section

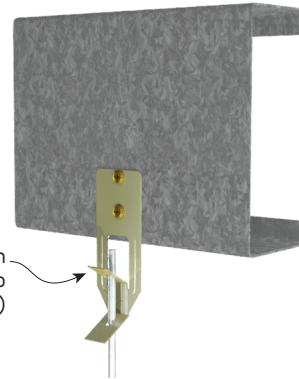
**Non-Fire Rated  
Typical Suspension Rod Clips**

Spring Adjustable Anchor  
to Suspension Rod Clip  
(C60LDF)



**FIGURE 7 Spring Adjustable Direct Fix Clip to Concrete**  
Perspective

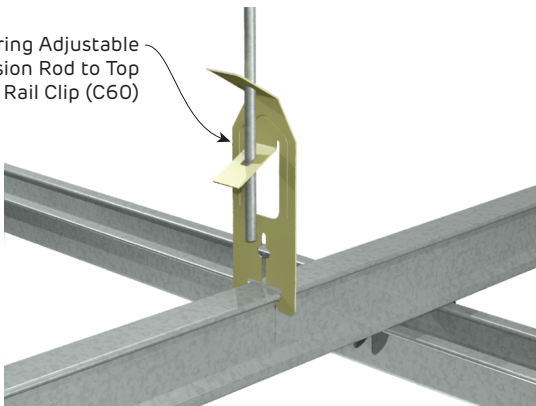
Spring Adjustable Purlin  
to Suspension Rod Clip  
(C60DF)



**FIGURE 8 Spring Adjustable Direct Fix Clip to Purlin**  
Perspective

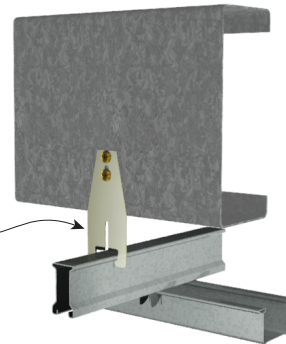
**Typical Top Cross Rail Clips**

Spring Adjustable  
Suspension Rod to Top  
Cross Rail Clip (C60)



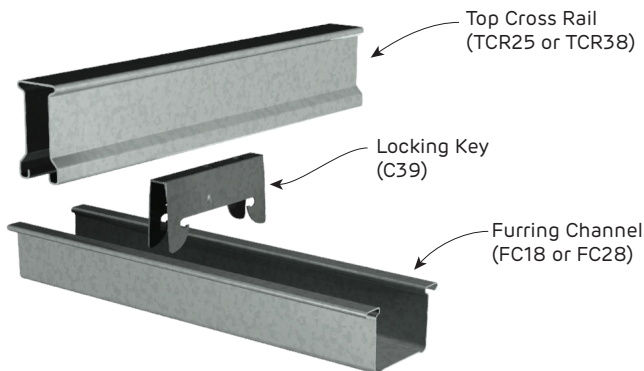
**FIGURE 9 Spring Adjustable Suspension Rod to TCR Clip**  
Perspective and Sections

Top Cross Rail to  
Purlin Clip (C66)



**FIGURE 10 Top Cross Rail Direct Fix Clip to Purlin**  
Perspective and Sections

**Locking Key**

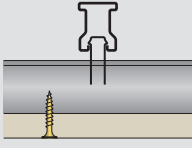


**FIGURE 11 Locking Key**  
Perspective



**Table 2 Top Cross Rail Ceiling Span Table - REGION A**

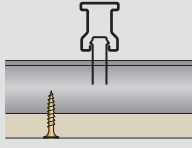
Refer to Section 2.3 for assistance determining the relevant wind pressures for a specific project.

<b>Top Cross Rail Span Table</b> Suspended ceiling lined with Createx and 28mm Furring channels (AFC28) at 400mm maximum spacing						Up to BCA Building Importance Level <b>3</b>	
Ultimate Wind Pressure $W_u$ (kPa)	Serviceability Wind Pressure $W_s$ (kPa)	Top Cross Rail	Top Cross Rail Spacing (mm)	Double Span		3 or more Spans	
				Hanger Spacing (mm)	Hanger Demand (kN)	Hanger Spacing (mm)	Hanger Demand (kN)
0.39	0.25	TCR25	900	1060	1.04	1150	1.03
			1050	980	1.12	1060	1.11
			1200	920	1.20	990	1.18
		TCR38	900	1270	1.24	1370	1.23
			1050	1170	1.34	1270	1.33
0.47	0.3	TCR25	900	1000	1.11	1080	1.10
			1050	920	1.19	1000	1.19
			1200	860	1.28	930	1.26
		TCR38	900	1190	1.32	1290	1.31
			1050	1100	1.43	1190	1.41
0.54	0.35	TCR25	900	950	1.17	1020	1.15
			1050	880	1.26	950	1.25
			1200	820	1.35	890	1.34
		TCR38	900	1130	1.39	1220	1.37
			1050	1050	1.51	1130	1.48
			1200	980	1.61	1060	1.59

- Table based upon downward (suction) and upward (uplift) pressures, intended for internal use only. Down-struts are required for uplift.
- Table includes self weight and 1 kg/m<sup>2</sup> insulation weight with an additional 3 kg/m<sup>2</sup> service load. No further allowance for additional point loads or live loads.
- Downstruts must be installed for TCR suspended ceilings in all buildings except air-conditioned hospitals, offices and shopping centres that are effectively sealed where the external walls have non-opening windows.
- Contact Siniat or a structural engineer to check ceiling for earthquake actions. Specific project information is required.
- Table refers to Siniat Furring Channels of 0.42mm Base Metal Thickness (BMT) of grade G550 steel and Siniat Top Cross Rails of 0.75mm BMT of grade G300, both with Zinalume™ AM150 corrosion protection. Maximum production lengths available are 6.0m
- Furring Channels checked for 2-or-more spans only. If required, contact Siniat for Single Span furring channel check.
- Designed in accordance with AS/NZS 4600:2018 Cold Formed Steel Structures and AS/NZS 2785:2000 Suspended Ceilings - Design and Installation.
- Wind pressures determined in accordance with AS/NZS 1170.2 Wind Actions.
- Connections to clips must be checked with the *Clip Capacity Table* in Section 5.1.
- Ultimate Limit State Load Case 1: 1.2G + Wu (Suction) + Q<sub>0.03kPa Service Load</sub>  
Ultimate Limit State Load Case 2: 0.9G + Wu (Uplift).
- Serviceability Limit State Load Case 1: G, with deflection limited to Span/500.
- Serviceability Limit State Load Case 2: G + Ws, with deflection limited to Span/200.
- Perimeter anchors at 600mm maximum centres and 100mm maximum from track ends with minimum 0.7 kN shear capacity.
- The nominated lateral pressures and deflection limits must be checked for suitability for a specific project.
- For BCA Building Importance Level 4, please contact Siniat.

**Table 3 Top Cross Rail Ceiling Span Table - REGION B**

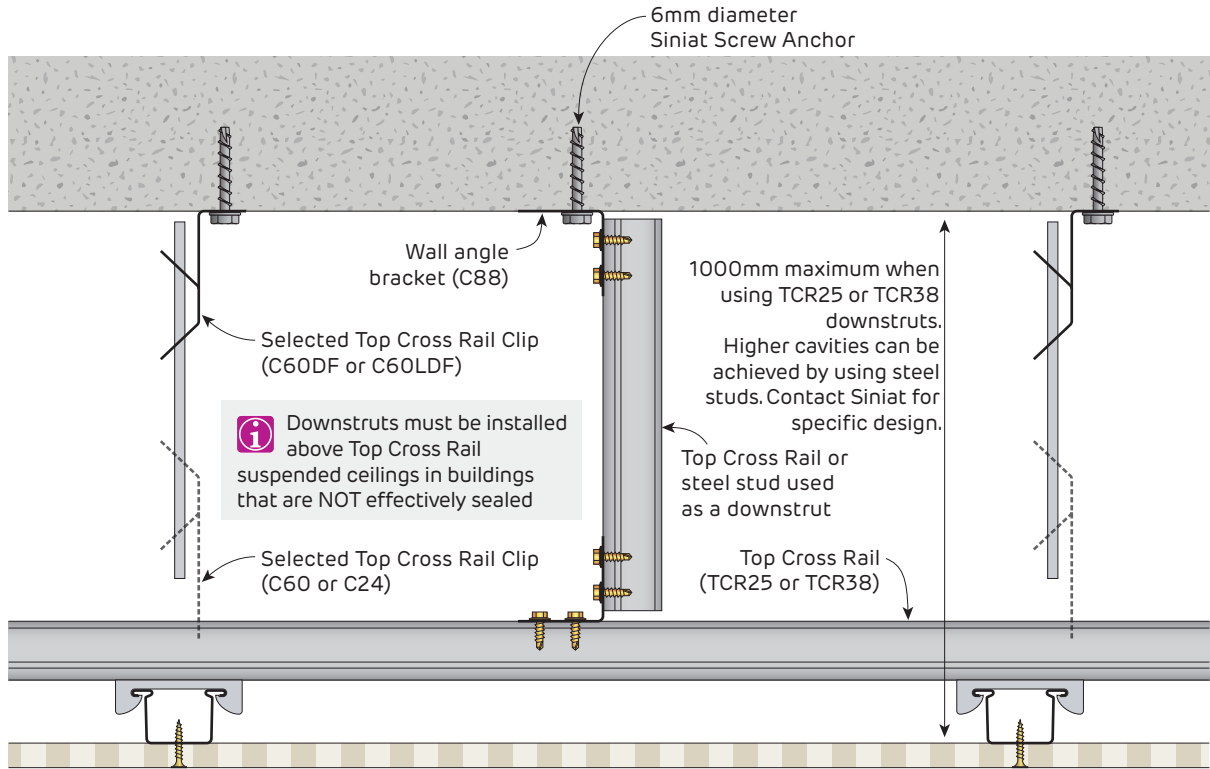
Refer to Section 2.3 for assistance determining the relevant wind pressures for a specific project.

Top Cross Rail Span Table Suspended ceiling lined with Createx and 28mm Furring channels (AFC28) at 400mm maximum spacing						Up to BCA Building Importance Level 3	
Ultimate Wind Pressure $W_u$ (kPa)	Serviceability Wind Pressure $W_s$ (kPa)	Top Cross Rail	Top Cross Rail Spacing (mm)	Double Span		3 or more Spans	
				Hanger Spacing (mm)	Hanger Demand (kN)	Hanger Spacing (mm)	Hanger Demand (kN)
0.59	0.25	TCR25	900	910	1.20	990	1.19
			1050	850	1.30	920	1.29
			1200	790	1.39	860	1.38
		TCR38	900	1090	1.43	1180	1.42
			1050	1010	1.55	1090	1.53
			1200	950	1.67	1020	1.64
0.71	0.3	TCR25	900	850	1.29	920	1.28
			1050	790	1.40	850	1.38
			1200	740	1.50	800	1.48
		TCR38	900	1020	1.55	1100	1.53
			1050	940	1.66	1020	1.65
			1200	860	1.74	950	1.76
0.83	0.35	TCR25	900	800	1.38	860	1.35
			1050	740	1.49	800	1.47
			1200	690	1.58	750	1.57
		TCR38	900	960	1.65	1030	1.62
			1050	870	1.75	950	1.74
			1200	760	1.74	830	1.74

- Table based upon downward (suction) and upward (uplift) pressures, intended for internal use only. Down-struts are required for uplift.
- Table includes self weight and 1 kg/m<sup>2</sup> insulation weight with an additional 3 kg/m<sup>2</sup> service load. No further allowance for additional point loads or live loads.
- Downstruts must be installed for TCR suspended ceilings in all buildings except air-conditioned hospitals, offices and shopping centres that are effectively sealed where the external walls have non-opening windows.
- Contact Siniat or a structural engineer to check ceiling for earthquake actions. Specific project information is required.
- Table refers to Siniat Furring Channels of 0.42mm Base Metal Thickness (BMT) of grade G550 steel and Siniat Top Cross Rails of 0.75mm BMT of grade G300, both with Zinalume™ AM150 corrosion protection. Maximum production lengths available are 6.0m
- Furring Channels checked for 2-or-more spans only. If required, contact Siniat for Single Span furring channel check.
- Designed in accordance with AS/NZS 4600:2018 Cold Formed Steel Structures and AS/NZS 2785:2000 Suspended Ceilings - Design and Installation.
- Wind pressures determined in accordance with AS/NZS 1170.2 Wind Actions.
- Connections to clips must be checked with the *Clip Capacity Table* in Section 5.1.
- Ultimate Limit State Load Case 1: 1.2G +  $W_u$  (Suction) +  $Q_{0.03kPa}$  Service Load  
Ultimate Limit State Load Case 2: 0.9G +  $W_u$  (Uplift).
- Serviceability Limit State Load Case 1: G, with deflection limited to Span/500.
- Serviceability Limit State Load Case 2: G +  $W_s$ , with deflection limited to Span/200.
- Perimeter anchors at 600mm maximum centres and 100mm maximum from track ends with minimum 0.7 kN shear capacity.
- The nominated lateral pressures and deflection limits must be checked for suitability for a specific project.
- For BCA Building Importance Level 4, please contact Siniat.



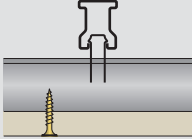
## Downstrut



**FIGURE 12 Downstrut**  
Section

**Table 4 Downstrut Table - REGION A**

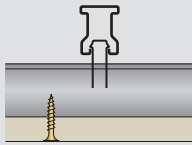
Refer to Section 2.3 for assistance determining the relevant wind pressures for a specific project.

Downstrut Interval Table (along Top Cross Rail) Suspended ceiling lined with Creutex and 28mm Furring channels (AFC28) at 400mm maximum spacing					Up to BCA Building Importance Level <b>3</b>
Ultimate Wind Pressure $W_U$ (kPa)	Serviceability Wind Pressure $W_S$ (kPa)	Top Cross Rail	Top Cross Rail Spacing (mm)	Double Span	3 or more Spans
				Maximum Downstrut Intervals (mm)	Maximum Downstrut Intervals (mm)
0.39	0.25	TCR25	900	1570	1670
			1050	1470	1570
			1200	1400	1490
		TCR38	900	1960	2070
			1050	1860	1960
			1200	1780	1870
0.47	0.3	TCR25	900	1430	1530
			1050	1340	1430
			1200	1260	1350
		TCR38	900	1820	1920
			1050	1720	1780
			1200	1630	1670
0.54	0.35	TCR25	900	1330	1430
			1050	1250	1330
			1200	1180	1260
		TCR38	900	1330	1770
			1050	1250	1640
			1200	1180	1540

1. Downstruts must be installed for TCR suspended ceilings in all buildings except air-conditioned hospitals, offices and shopping centres that are effectively sealed where the external walls have non-opening windows.

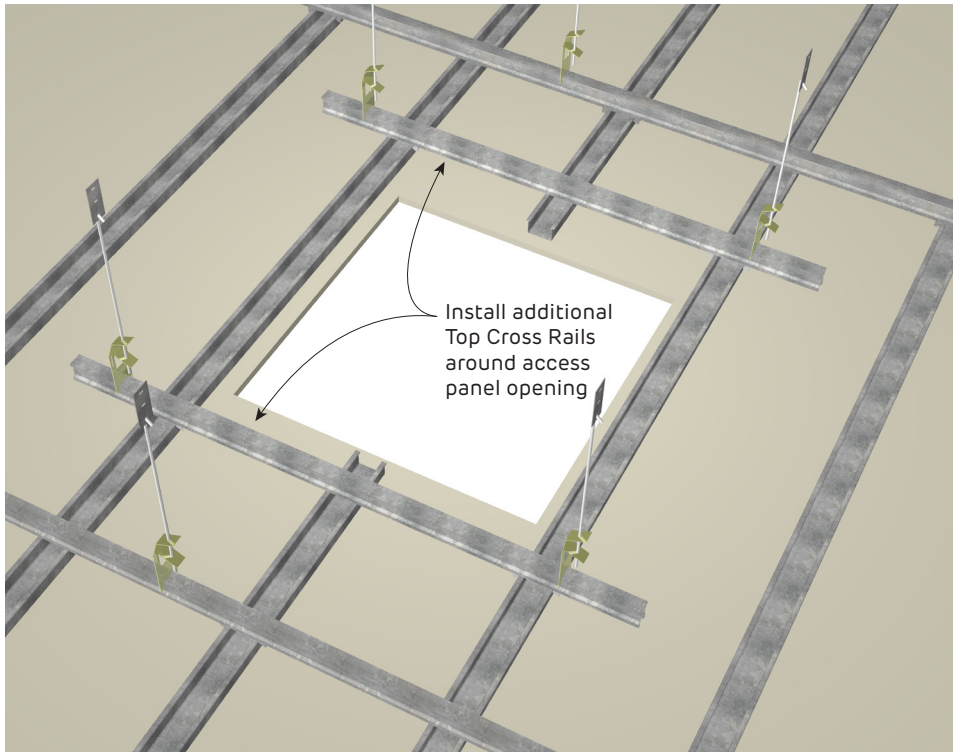
**Table 5 Downstrut Table - REGION B**

Refer to Section 2.3 for assistance determining the relevant wind pressures for a specific project.

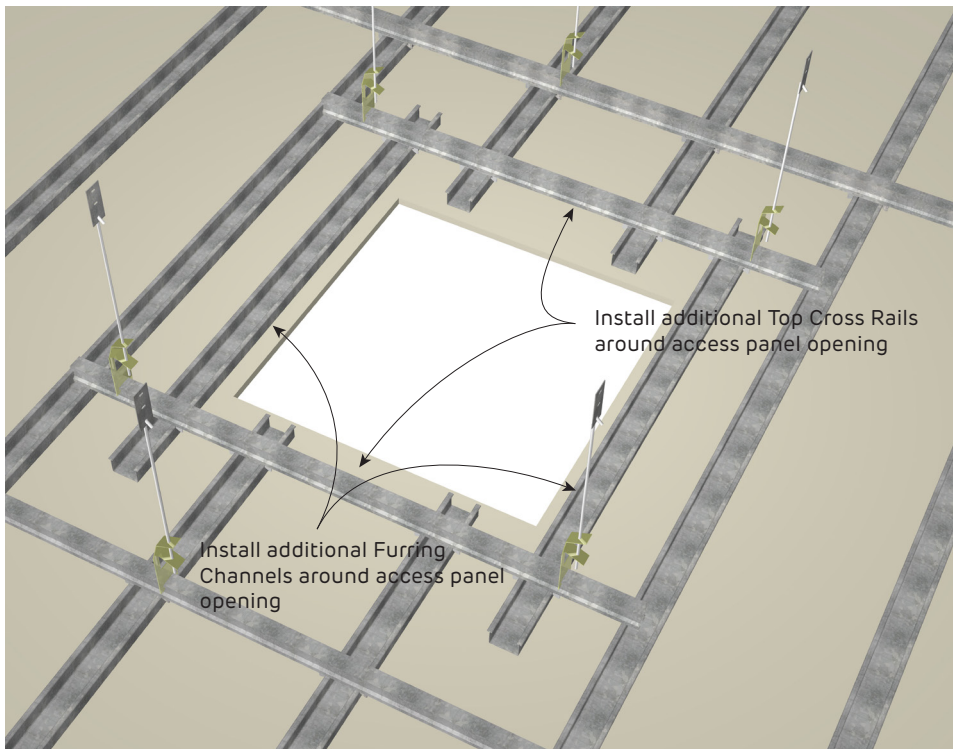
Downstrut Interval Table (along Top Cross Rail) Suspended ceiling lined with Createx and 28mm Furring channels (AFC28) at 400mm maximum spacing					Up to BCA Building Importance Level <b>3</b>
Ultimate Wind Pressure $W_u$ (kPa)	Serviceability Wind Pressure $W_s$ (kPa)	Top Cross Rail	Top Cross Rail Spacing (mm)	Double Span	3 or more Spans
				Maximum Downstrut Intervals (mm)	Maximum Downstrut Intervals (mm)
0.59	0.25	TCR25	900	1280	1360
			1050	1190	1280
			1200	1120	1200
		TCR38	900	1650	1690
			1050	1550	1560
			1200	1470	1460
0.71	0.3	TCR25	900	1160	1100
			1050	1090	1160
			1200	1020	1100
		TCR38	900	1520	1520
			1050	1410	1400
			1200	1230	1310
0.83	0.35	TCR25	900	1080	1150
			1050	1000	1080
			1200	930	1010
		TCR38	900	1380	1390
			1050	1180	1290
			1200	1030	1130

- Downstruts must be installed for TCR suspended ceilings in all buildings except air-conditioned hospitals, offices and shopping centres that are effectively sealed where the external walls have non-opening windows.

## Access Panel



**FIGURE 15** Createx Access Panel Framing  
Perspective



**FIGURE 16** Createx Access Panel Framing  
Perspective



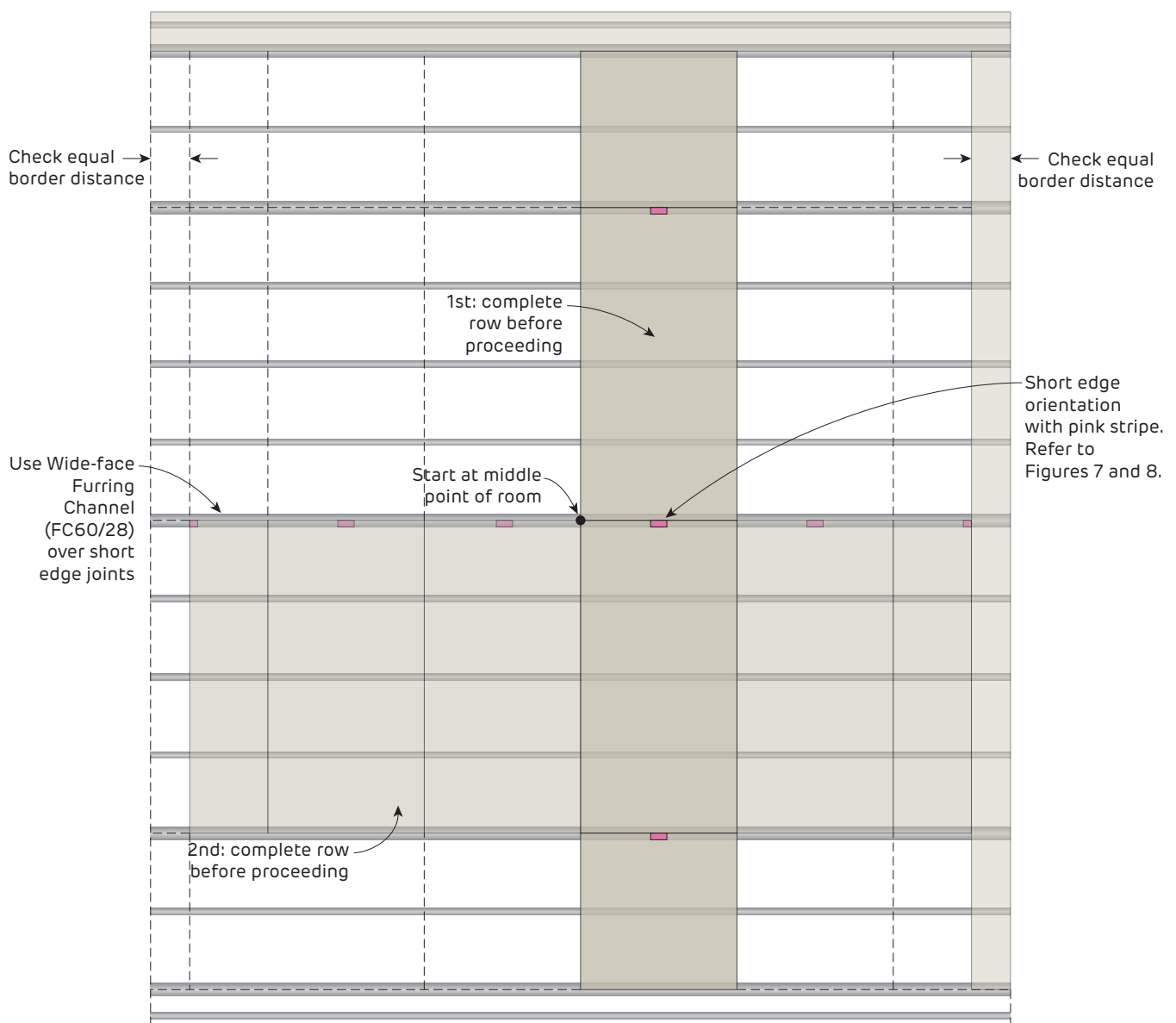
## Layout

Start sheeting from the centre of the room.

Install **createx** ceilings perpendicular to framing members.

Fix short edges on a Wide-face Furring Channel (F60/28).

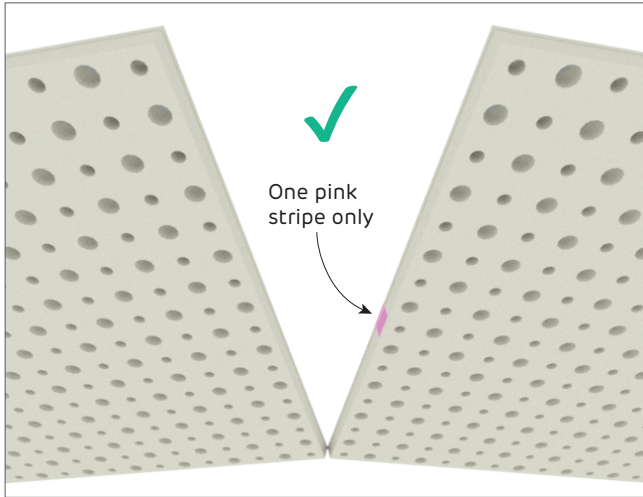
Install one entire row in each direction before proceeding. Refer to Figure 17.



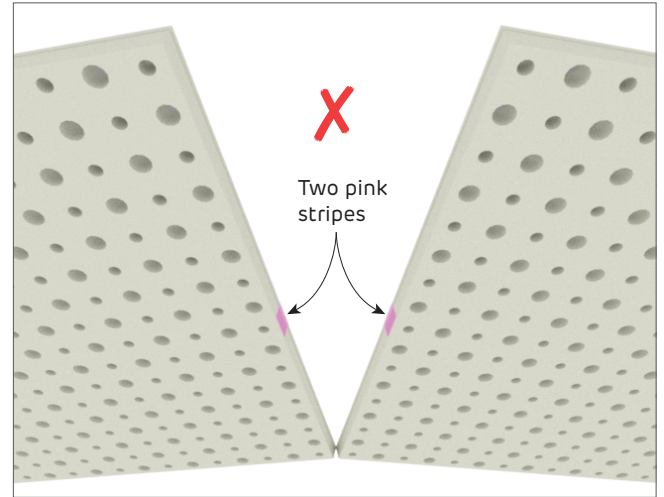
**FIGURE 17 Ceiling Layout Plan**

## Sheet Orientation Along Short Edges

Align the short edges of **createx** sheets so that the pink paint stripe does not coincide with each other. Refer to Figure 18 for the correct orientation.

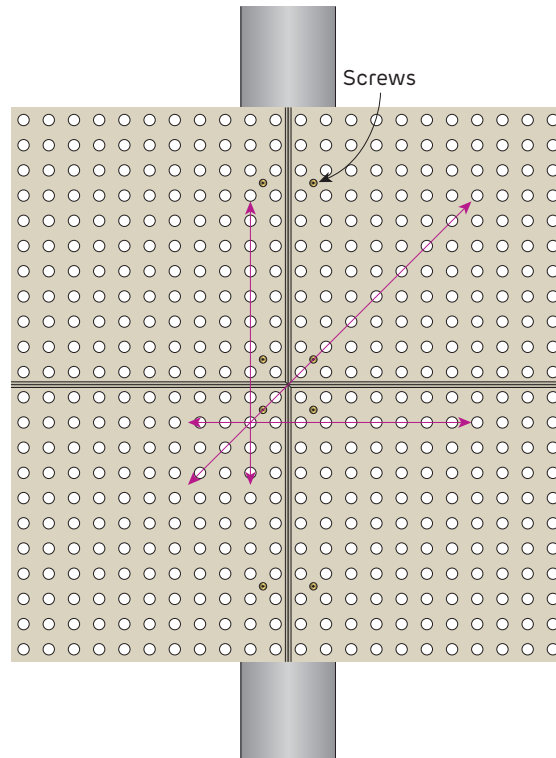


**FIGURE 18 Correct Short Edge Orientation**  
Perspective



**FIGURE 19 Incorrect Short Edge Orientation**  
Perspective

## Perforation Alignment



**FIGURE 20 Perforation Alignment**  
Plan



## Fixing

Use the 'Screw Only Method'. Adhesive is not permitted.
Drive screws to just below the sheet surface, taking care not to break the paper linerboard. For over-driven screws, install another screw 20mm away. Leave or remove the over-driven screw and patch.
Press <b>createx</b> firmly on to the grid when screwing.
Start fastening from the corner, where the plasterboard meets previously attached boards.
Fasten long edge first and then short edges.
Use a straight edge across adjoining sheets to check both sheets are level across the joints. If necessary, adjust the level of the sheets by unscrewing perimeter screws slightly, so both sheets are level across joints.

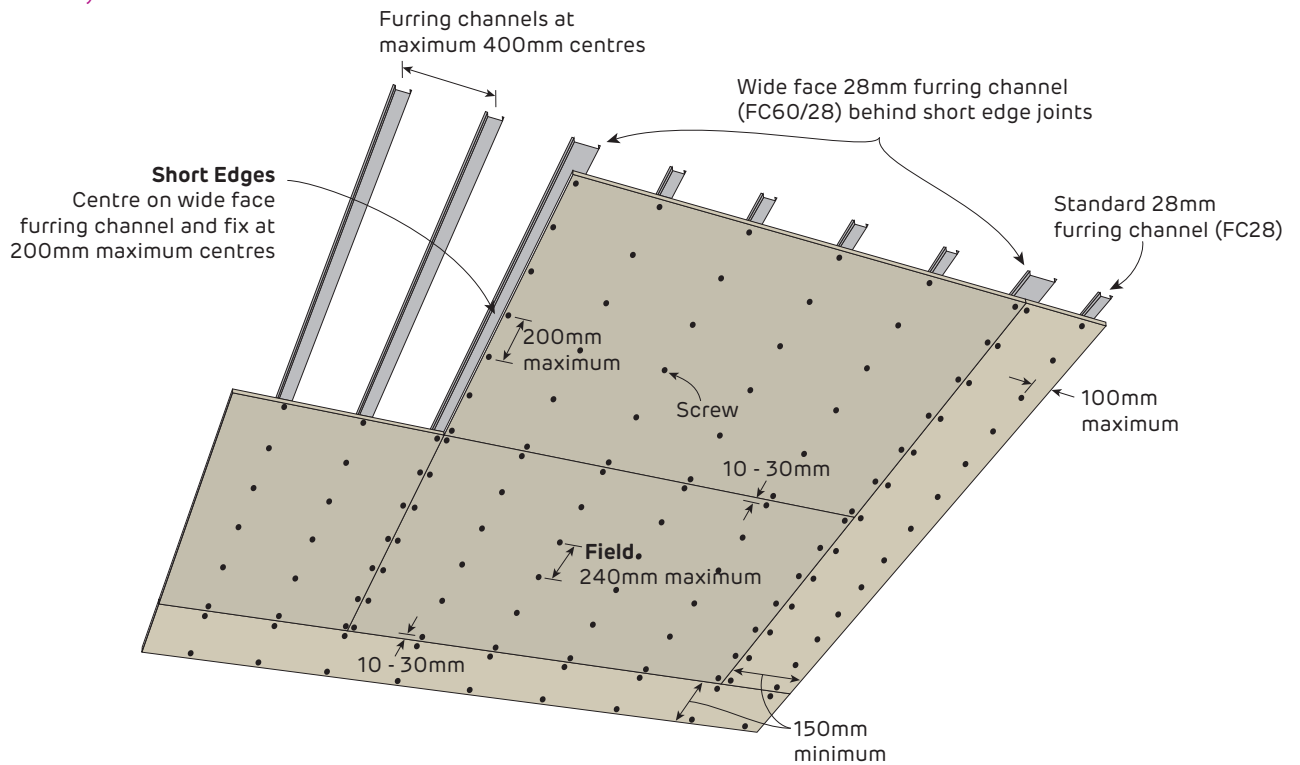
### Screw Type and Minimum Size for the Installation of Plasterboard to Steel

Plasterboard Thickness	1st Layer
12.5mm	6g x 25mm screw

For steel  $\leq 0.75$ mm BMT, use fine thread needle point screws.

For steel  $\geq 0.75$ mm BMT, use fine thread drill point screws.

**FIGURE 21 Createx Internal Ceiling - 1 Layer**  
 Screw Only Method



### Fixing Pattern Table

Sheet Width	Location	Screw Fixing Pattern
1200mm	Field	S S S S S S (6)
	Short edges (butt joints)	S S S S S S S (7)

S = One screw

### Maximum Ultimate Limit State Wind Load Table (kPa)

Plasterboard Thickness	Maximum Ceiling Frame Spacing	
	400mm	300mm
12.5mm	1.50	2.05

1. Calculations do not include the framing which must be independently designed to suit the desired load.
2. Calculations include a ceiling insulation with maximum weight of 1.05 kg/m<sup>2</sup> (equivalent to Pink® Partition 75mm 14kg/m<sup>3</sup> R1.9 Batts).
3. If higher internal wind pressures are expected, please contact Siniat for specific design.



## Finishing

### Jointing

Jointing must not be conducted until all ceiling services and access panels are installed in the ceiling, otherwise the excessive vibration may cause joint cracking or peaking.

Use a wet brush to clean dust from joints after fixing the boards.

Prime site cut edges with a PVA based primer (ie: one part Bondcrete to four parts water).

Slightly overfill joints with **mastatape-in** jointing compound and allow to dry. It is recommended to use a sausage caulking gun. After allowing to dry (approximately 3 to 5 hours depending on weather conditions but do not leave overnight), scrape off excess jointing compound to level the joint. Refer to Figure 22.

Use **mastalite**, **mastaglide**, or **mastaline** for finishing joints and screw heads. For more information refer to Section 7.3.

Do not obstruct perforations during jointing.



**FIGURE 22 V Edge Jointing**  
Section

### Sanding

Sanding is a critical part of achieving a high quality finish. Care should be taken when sanding joints to achieve a smooth surface.

Lightly sand to a smooth even surface using 180 to 220 grit sandpaper or sanding mesh. Care must be taken to not scuff the paper linerboard especially around perforations while sanding.

### Painting

A three coat paint system must be applied in accordance with Australian Standard AS/NZS 2311, *Guide to the painting of buildings*. Both the quality of the paint and how it is applied have a large effect on the finished appearance of the **createx** plasterboard.

Apply the paint with a short napped roller and avoid the application of excess paint at any time.



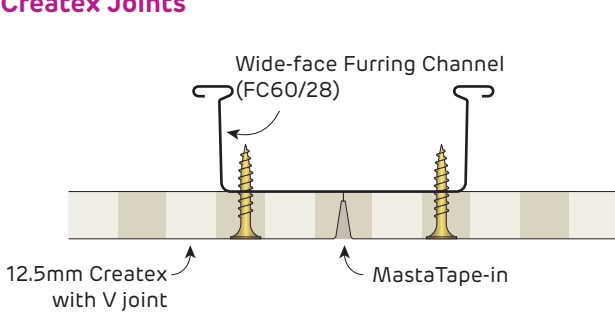
> Only use a roller application for painting. Roller application applies a uniform texture over the entire surface and ensures the paint does not fill the perforations or contact the acoustic felt on the back of the plasterboard.

> Spray painting is not permitted.

> For more information on finishing plasterboard refer to Section 7.

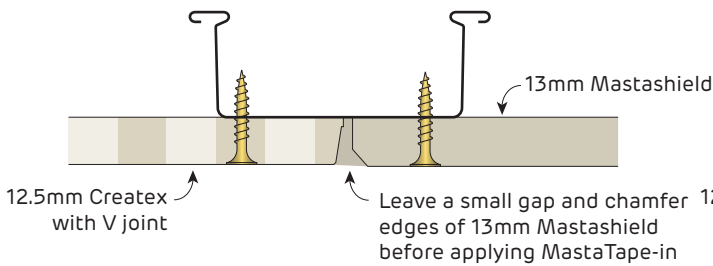


**Non-Fire Rated**  
**Creutex Joints**

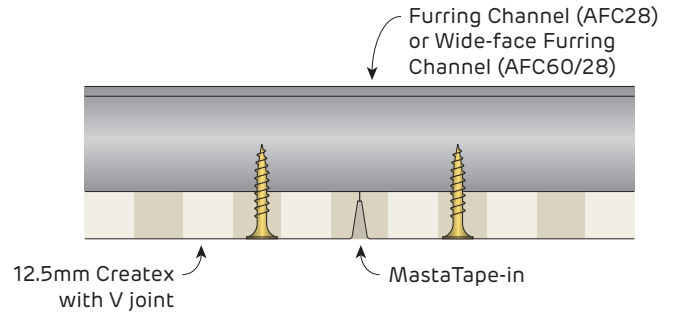


**FIGURE 23 Creutex with V Joint**  
Using Wide-face Furring Channel Section

**i** If necessary, use packers to ensure easy jointing of 12.5mm Creutex with 13mm Mastashield

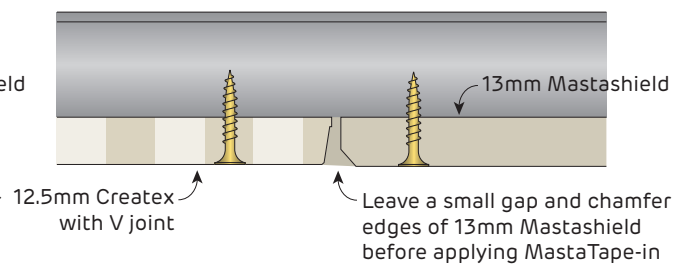


**FIGURE 25 Creutex to ceiling border**  
Using Wide-face Furring Channel Section



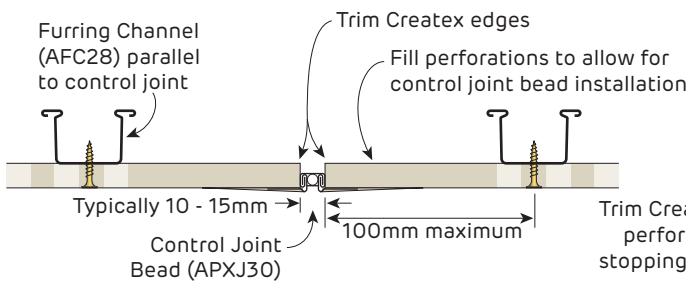
**FIGURE 24 Creutex with V Joint**  
Elevation

**i** Prime any cut edges of Creutex and plasterboard with PVA based primer when MastaTape-in is used for jointing

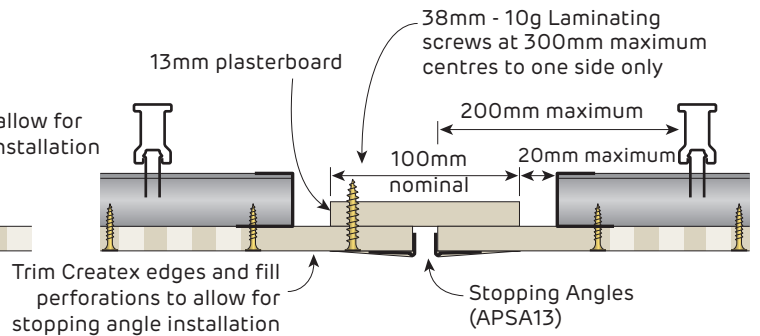


**FIGURE 26 Creutex to ceiling border**  
Elevation

**Control Joints**



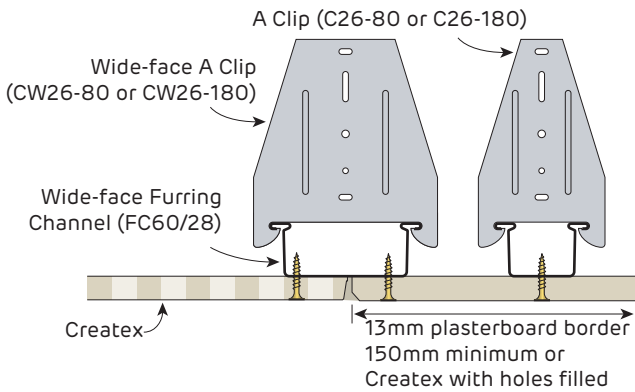
**FIGURE 27 Control Joint - Control Joint Bead**  
Parallel to furring channel Section



**FIGURE 28 Control Joint - Stopping Angles**  
Perpendicular to furring channel Section

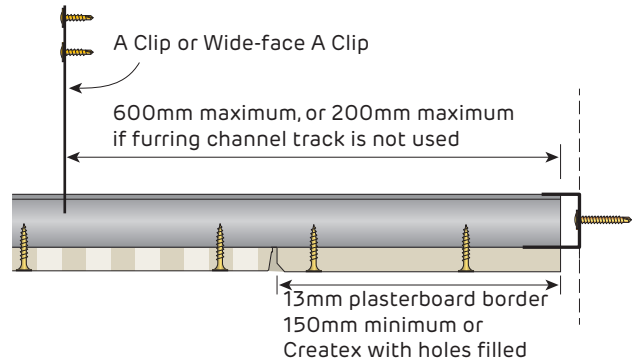


**Non-Fire Rated**  
**Creutex Perimeter Details**



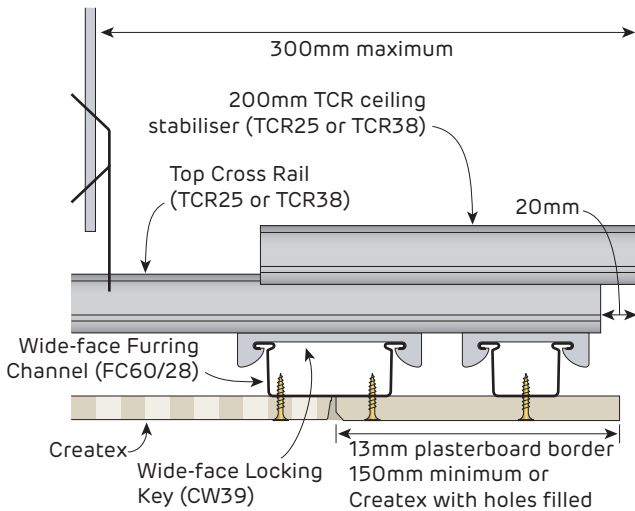
**FIGURE 29 Perimeter Detail - Border**  
Creutex Direct Fix Ceiling Frame Section

**i** The recommended ceiling border detail is to continue the Creutex to the wall and fill holes with MastaTape-in and then MastaLite as a finishing coat



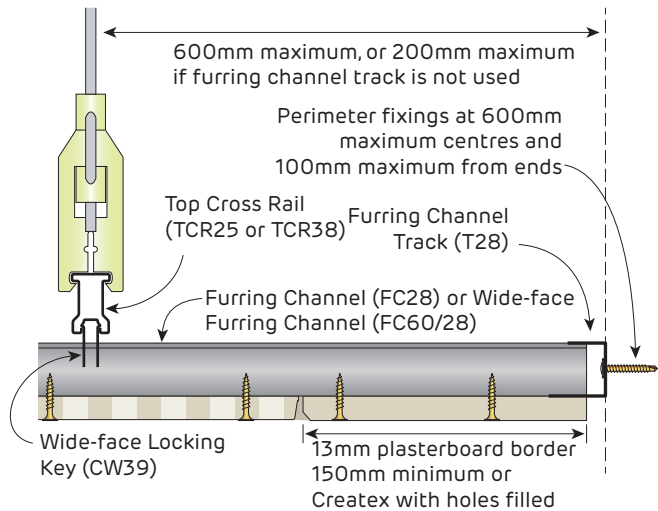
**FIGURE 30 Perimeter Detail - Border**  
Creutex Direct Fix Ceiling Frame Section

**i** If necessary, use packers to ensure easy jointing of 12.5mm Creutex with 13mm Mastashield

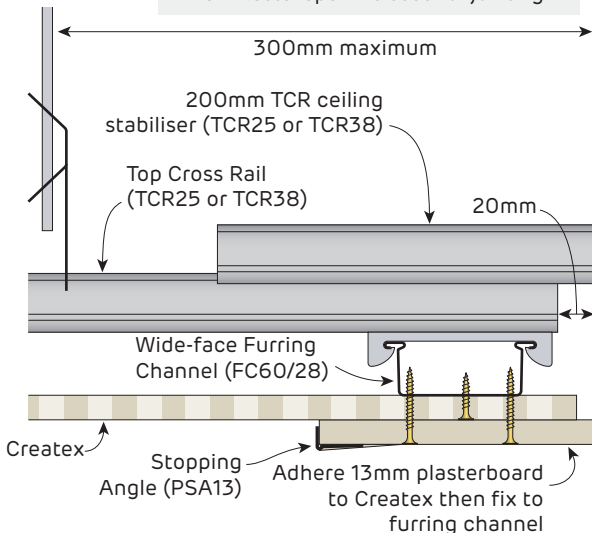


**FIGURE 31 Perimeter Detail - Border**  
Creutex Suspended Ceiling Frame Section

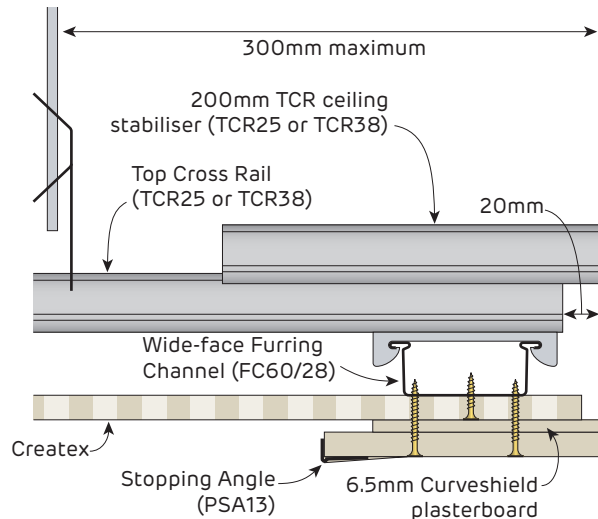
**i** Prime any cut edges of Creutex and plasterboard with PVA based primer when MastaTape-in is used for jointing



**FIGURE 32 Perimeter Detail - Border**  
Creutex Suspended Ceiling Frame Section



**FIGURE 33 Perimeter Detail - Proud Border**  
Creutex Suspended Ceiling Frame Section

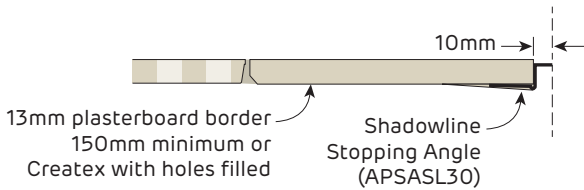


**FIGURE 34 Perimeter Detail - Proud Shadow Border**  
Creutex Suspended Ceiling Frame Section

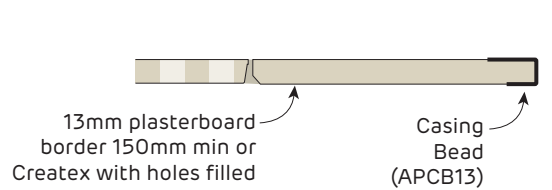


**Non-Fire Rated**

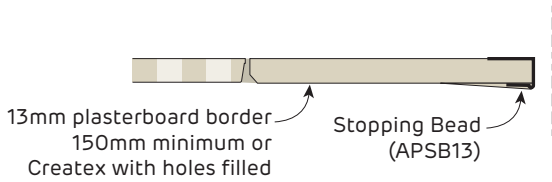
**Ceiling Perimeter Finishing Details**



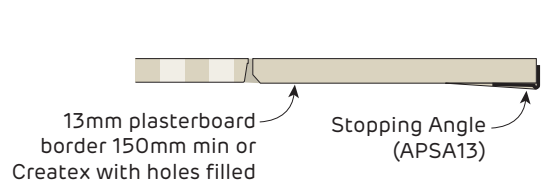
**FIGURE 35 Finishing Detail - Shadowline**  
Section



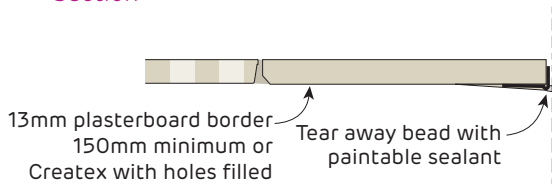
**FIGURE 36 Finishing Detail - Casing Bead**  
Section



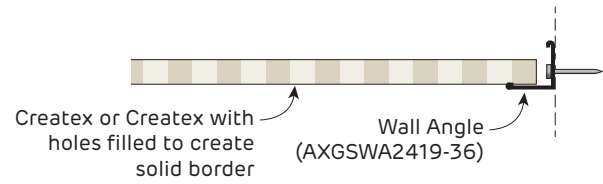
**FIGURE 37 Finishing Detail - Stopping Bead**  
Section




**FIGURE 38 Finishing Detail - Stopping Angle**  
Section



**FIGURE 39 Finishing Detail - Tear Away Bead**  
Section



**FIGURE 40 Finishing Detail - Wall Angle**  
Section

 Ceilings using a square set finishing detail have low tolerance for building movement and are more prone to cracking and joint peaking