



smartwall
Installation Guide

Western Australia Only

Disclaimer

Products manufactured and construction systems designed by Etex Australia Pty Ltd and branded Siniat, are produced in accordance with the Building Code of Australia and relevant Australian Standards. Information in this document is to be used as a guide only and is subject to project approval as many aspects of construction are not comprehensively covered. It is the responsibility of the project to determine if our products, construction systems and installation details are suitable for the intended application and they meet the relevant building codes and project requirements. It is also the project's responsibility to ensure third party products have the appropriate certification for use with Siniat products and construction systems. Etex Australia Pty Ltd will not be held responsible for any claims resulting from the installation of Siniat products or other associated products not in accordance with the requirements of the manufacturer's technical literature or relevant Australian Standards, or for situations not covered by our certification reports.

Siniat technical information is regularly updated. To ensure this document is current with the latest information, visit [siniat.com.au](https://www.siniat.com.au) or contact Siniat Customer Service Centre on **1300 724 505**

Warranty

Siniat products are guaranteed by a 10 Year Warranty.

Visit [siniat.com.au/warranty](https://www.siniat.com.au/warranty)

Version 1

February 2025

About Siniat

Siniat is one of the Etex Group's flagship commercial brands, and one of the leading global manufacturers of interior and exterior materials for drywall construction.

In Australia, Etex has Siniat manufacturing facilities located in Sydney, Melbourne, Bundaberg, Brisbane and Perth. Etex supplies Siniat branded plasterboard, compounds, cornice, steel profiles and associated products and systems to the Australian building industry through its national distribution network.

Siniat's comprehensive range of quality wall and ceiling lining products are developed with specific characteristics to enhance performance and provide fire, water, acoustic and decorative solutions to all construction projects.

The Siniat team is committed to providing excellent technical service and sales support to help with innovative solutions for your next project.

Download Siniat Documents



Contents

INTRODUCTION	4
1 SINIAT PRODUCT RANGE	5
2 BUILDING WITH LIGHTWEIGHT CONSTRUCTION	6
2.1 Materials	6
2.2 Care and Use	7
3 INSTALLATION	10
3.1 Walls	10
3.2 Wet Areas	16



Smartwall

Siniat **smartwall** is a purpose designed complete plasterboard wall lining system for low rise residential dwellings in Western Australia. **smartwall** allows a wide range of architectural styles that is uniquely designed to enable the lining of dry masonry walls. Providing a clean and level finish for all wall surfaces and window reveals, **smartwall** also allows for the correction of wall alignments.

smartwall plasterboard sheets come with a square edge for cornice and skirting lines and a recessed edge for plaster jointing to a smooth surface ready for further decoration.

A fast, dry alternative to cement render and set plaster finishes, **smartwall** minimises potential delays to building projects associated with heavy, wet construction. **smartwall** is suitable for lining masonry walls in residential houses that do not become wet during service.

Where required, Siniat **watershield** is used in wet areas such as bathrooms, showers, laundries, sanitary compartments and kitchens.

'Masonry' in this installation guide includes clay or calcium silicate bricks and concrete blocks.

This installation guide is intended to be used in conjunction with the Siniat '**Plasterboard Installation Guide**' available from the Siniat website.

Features

- > A clean, easily painted wall surface finish superior to cement render
- > Straighter walls - less dependent on plastering to achieve a level finish
- > Adhered directly to masonry using Siniat **mastabond** masonry adhesive
- > Eliminates damaging render splashes.



Siniat Product Range

Recommended Application of Siniat Plasterboards

Plasterboard	Typical Use	Walls	Ceilings
smartwall	Standard wall lining over masonry walls	✓	
watershield	Walls in wet areas in bathrooms, showers, laundries, toilets and kitchens	✓	

* For information on other Siniat products, refer to www.siniat.com.au

Plasterboard

Plasterboard	Thickness (mm)	Width (mm)	Length (mm)						Weight (kg/m ²)	Properties	
			2400	2700	3000	3600	4200	4800			6000
smartwall	10	1200							• +	6.4	
		1350							• +		
watershield	10	1200	•	•	•	•	•	•		7.5	
		1350	•		•	•	•	•			
	13	1200	•	•	•	•	•			9.6	
		1350			•	•					

• Stock item in WA + Available in Square Edge/Recessed Edge in WA.

Weights indicated are nominal. Check website for the most up to date information.

Other sizes available, minimum order quantity and lead times apply.

Recessed/Recessed edge types are standard. Other edge types (Square/Recessed, Square/Square) are available, minimum order quantity and lead times apply.

Adhesive

Name	Size	Type	Application
mastabond	20 kg bag	Powder	Masonry walls



Building with Lightweight Construction

Etex Australia offers a wide range of solutions for lightweight construction including metal framing, plasterboard linings, ceiling tiles, adhesives, jointing compounds, fire sealant and cornice.

Siniat wall and ceiling linings are available with a wide range of properties for different applications from impact resistant plasterboard to aesthetic ceiling linings that absorb sound.

Along with providing these solutions, Siniat offers a suite of Knowhow services to help bring your project to life from instant online calculators and system selectors to personal technical advice and all backed by a 10 year Siniat warranty.

2.1 Materials

Fire Hazard Properties

The National Construction Code (NCC) regulates the fire hazard properties of coverings and lining materials in buildings according to NCC 2022 Volume One, C2D11. Floor linings and coverings must have a high enough critical radiant flux to comply with NCC 2022 Volume One, C2D11, while wall and ceiling linings must have a low enough group number. The group number indicates how quickly wall and ceiling linings spread fire, with Group 1 products ranked the slowest and Group 4 the fastest.

Product	Group Number	Average Specific Extinction Area (m ² /kg)
Smartwall	1	less than 250
Watershield	1	less than 250

Fire Hazard Property Report



Fire Hazard Properties and Combustibility



2.2 Care and Use

Storage, Delivery and Handling

Wall and ceiling linings must be kept dry and should be stacked clear of the floor using supports not more than 600mm apart as shown in Figure 1.

Remove plastic wrapping from plasterboard and accessories soon after storing in a location that is protected from the weather. This will prevent moisture being trapped.

If outdoor storage is unavoidable, linings and accessories should be fully protected from the weather temporarily.

Plasterboard that has been exposed to direct sunlight, or has been fixed and left unpainted for long periods, may become discoloured. If this happens, it must be sealed with a solvent borne stain sealer undercoat as recommended by the paint manufacturer.

Plasterboard ceilings should not be left unpainted as they may absorb moisture from the atmosphere and sag. Plasterboard finishing compound must not be left unpainted as it becomes susceptible to moisture absorption and can develop shrinkage defects or become powdery and flake off if painting is attempted.

To reduce the possibility of damage to plasterboard, arrange delivery to site immediately before installation. During delivery, care should be taken not to damage the surface or edges the plasterboard sheets.

Exposure to excessive humidity during storage can result in plasterboard becoming damp and soft, and may appear defective. In this case allow the plasterboard to dry out and handle with care during installation.

To help protect plasterboard from absorbing humidity:

- > Avoid open sources of water such as wet floors
- > Wrap the plasterboard temporarily with plastic overnight when storing outside
- > Provide ventilation
- > Install soon after delivery
- > Install during dry weather for best results.

Store Siniat steel products where they are not in constant contact with water or in wet environments for extended periods. Avoid exposure to airborne contaminants such as sea spray.

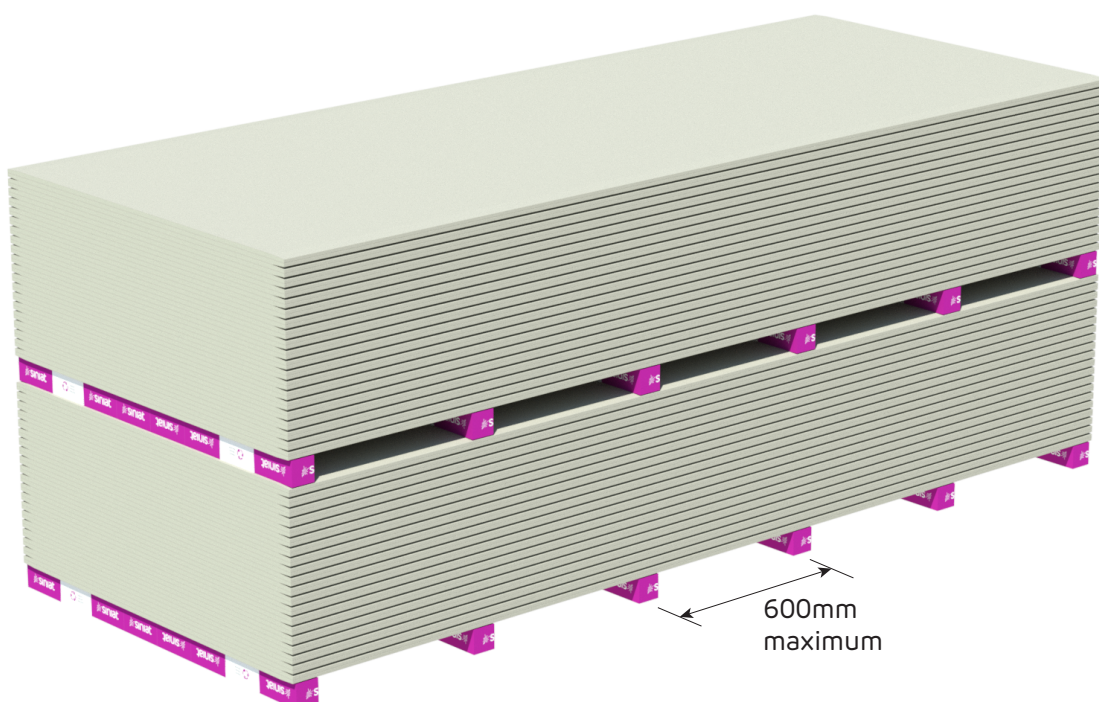

FIGURE 1 Correct Plasterboard Storage



Weather Protection

Siniat plasterboard must only be installed in a building that is weathertight. Particular care must be taken in areas of high humidity and coastal areas subject to salt spray. Complete all exterior doors, walls, windows and the roof before installing plasterboard. Prevent rain from entering buildings, avoid water on floors or other sources of open water and allow wet concrete or masonry to dry. These precautions will reduce excessive humidity that may be absorbed by timber or unpainted plasterboard and minimise defects caused by timber shrinkage or moist plasterboard.

Siniat plasterboard installed on the exterior side of external wall framing must be protected from the weather until moisture barriers and external cladding are installed. Protect plasterboard from water pooling at ground level.

Condensation and Ventilation

Condensation of water on a surface occurs when the temperature of a building element falls below the dew point temperature. Moisture from the air then condenses on the surface.

Condensation onto either the face or back of plasterboard and associated substrate framing must be avoided. Insufficient protection from condensation can result in plasterboard joint distortion, sagging, mould growth, fastener popping and corrosion on steel framing.

Many inter-related factors must be taken into account to control condensation. Good practice is to make use of wall and ceiling insulation, vapour barriers, and especially ventilation.

Siniat plasterboard must only be installed in a well ventilated area. Ventilation is crucial to the longevity of all building materials as it controls the indoor air quality. Therefore appropriate ventilation must be considered for the spaces in walls, under floors and in particular under roofs and soffits.



To minimise the effects of condensation:

- > Use **watershield** to increase protection against moisture.
- > Use moisture barriers, sarking, and insulation. However, it is important that the right type is selected for the construction type and that it is installed correctly. [Refer to the manufacturer's specifications]
- > Use foil backed insulation under metal roofs which are susceptible to forming condensation.
- > Install eave vents, gable vents and roof ventilators in the roof cavity.
- > Remove humidity from bathrooms via an exhaust fan to the outside.
- > Use a quality paint system to provide protection against paint peeling and condensation soaking into plasterboard and compounds.
- > Ensure the building design controls condensation on the steel components so they are not constantly wet.

In hot and humid climates where the building is air-conditioned below the dew point of the outside air, the wall and ceiling framing members and internal linings should be fully protected by moisture barriers to separate them from the humid external air. The moisture barriers should be thermally insulated to maintain them at a temperature above the dew point.



Exposure to High Humidity

Plasterboard exposed to high humidity (above 90%) for an extended period, may effect the plasterboards integrity and therefore its ability to perform its intended function.

For rooms with intermittent periods of high humidity such as bathrooms or basements where plasterboard is installed, a source of ventilation is required to enable removal of excess moisture, such as an open window or exhaust fan.

Ceilings in rooms such as indoor swimming pools and communal showers are subject to long periods of high humidity (above 90%). The use of plasterboard on these ceilings is not guaranteed by Etex Australia.

watershield completely covered with a waterproof membrane complying with *AS/NZS 4858:2004 Wet Area Membranes* may be used for walls in rooms subject to long periods of high relative humidity. Vertical junctions and wall to floor junctions must also be waterproof, refer to Section 3.3 Wet Areas.



In areas where high humidity is likely (ie: under concrete slabs with concrete block walls) consider closer framing intervals for ceiling linings to limit sag

Exposure to Water

Plasterboard that has become wet during its service life must be assessed for damage and then either repaired or replaced.

The Onboard referred to below may be used as a guide for determining if the plasterboard needs repair or replacement.

Exposure to Excessive Heat

OnBoard - Assessing Wet Plasterboard



Plasterboard is an ideal building material for normal ambient temperatures. It is not suitable for long periods at elevated temperatures such as installed near fireplace flues or chimneys. Fire resistant plasterboard is no exception. It is designed to slow down a fire, not to resist constant elevated temperatures.

The effect of high temperatures on plasterboard is to chemically dehydrate the core. This process generally begins at around 80°C but can occur at lower temperatures under certain conditions.

AS/NZS 2589:2017, Gypsum linings – Application and finishing, states that plasterboard must not be exposed to temperatures above 52°C for prolonged periods.

Heat generating appliances have installation instructions for the correct distances between plasterboard linings and heat sources. The *National Construction Code (NCC)* also has requirements for installation of heating appliances.

Glass or Stainless Steel Splashback

AS/NZS 5601.1-2013 General Gas Installations allows plasterboard to be used behind splashbacks near domestic gas burners as follows:

- > Behind ceramic tiles any plasterboard may be used if the ceramic tiles are minimum 5mm thick
- > If clearance to glass or stainless steel splashback is 200mm* or more then any plasterboard may be used
- > If clearance to glass splashback is less than 200mm* then 10mm plasterboard may be used if the glass is marked as 'toughened safety glass'
- > Clearance to stainless steel splashback is less than 200mm* then 6mm fibre cement over 10mm plasterboard may be used if the steel is at least 0.4mm thick.

*Clearance is measured from the edge of the nearest burner to the splashback.



3.1 Walls

General Requirements

Install control joints in plasterboard walls:

- > At 12m maximum intervals
- > At 4.2m maximum intervals when tiled
- > At all control joints in the masonry wall
- > At any change in the substrate
- > At the floor line in walls of frame construction stairways. Cover gap with a moulding fastened to one edge.

Install all services prior to **smartwall** plasterboard being fixed into place.

Attach all fixtures to the masonry wall. To prevent distortion of the **smartwall** sheets around the point of attachment, apply additional daubs of **mastabond** masonry adhesive where the fixture is to be located.

All masonry walls must be reasonably dry before the installing **smartwall** sheets.

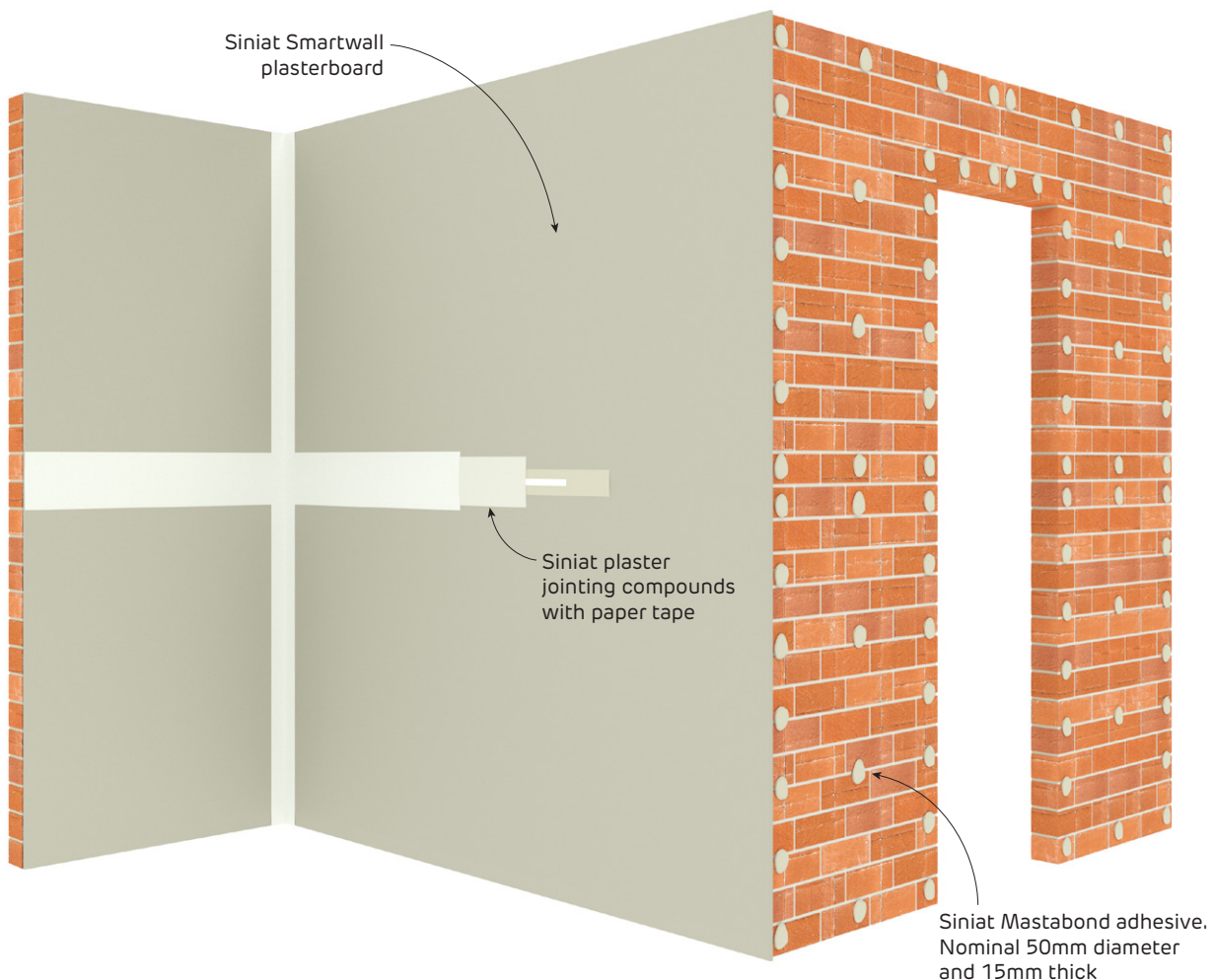

FIGURE 2 Typical Smartwall Internal Wall Installation



Plasterboard Layout

Vertical joints must be 200mm minimum from the edge of any opening such as windows and doorways to minimise cracking at the joints.

Horizontal Layout

Stagger butt joints by 600mm minimum on adjoining sheets.



> Install plasterboard sheets horizontally when practical reduce the effect of glancing light.

> Minimise butt joints by using long sheets.

Plasterboard Fixing

Masonry Adhesive Method

Masonry surfaces are to be clean, dry, and free from oil, dust, release agents and other contaminants. If the masonry wall surface is contaminated, then it must be prepared to provide a suitable surface for adhesion.

Scrape walls using a floor scraper to remove any excess mortar. Irregularities in wall surface must not exceed 15mm.

Strike a chalk line on the ceiling and floor as a guide to align the face of the **smartwall** sheets and establish a true wall plane before commencing installation.

Apply **mastabond** masonry adhesive over masonry walls using a 75mm broadknife, in 50mm diameter and 15mm high daubs. **mastabond** masonry adhesive is a setting compound, so do not mix after setting or hardening has commenced.

Install **smartwall** sheets immediately after **mastabond** daubs have been applied to a masonry wall. Final positioning can be made to the sheets after the initial grab.

Use a straightedge to position the smartwall boards into alignment vertically, horizontally and diagonally. Also check lines along cornice and skirting.



FIGURE 3 Internal Wall - 1 Layer Horizontal
Masonry Adhesive Method

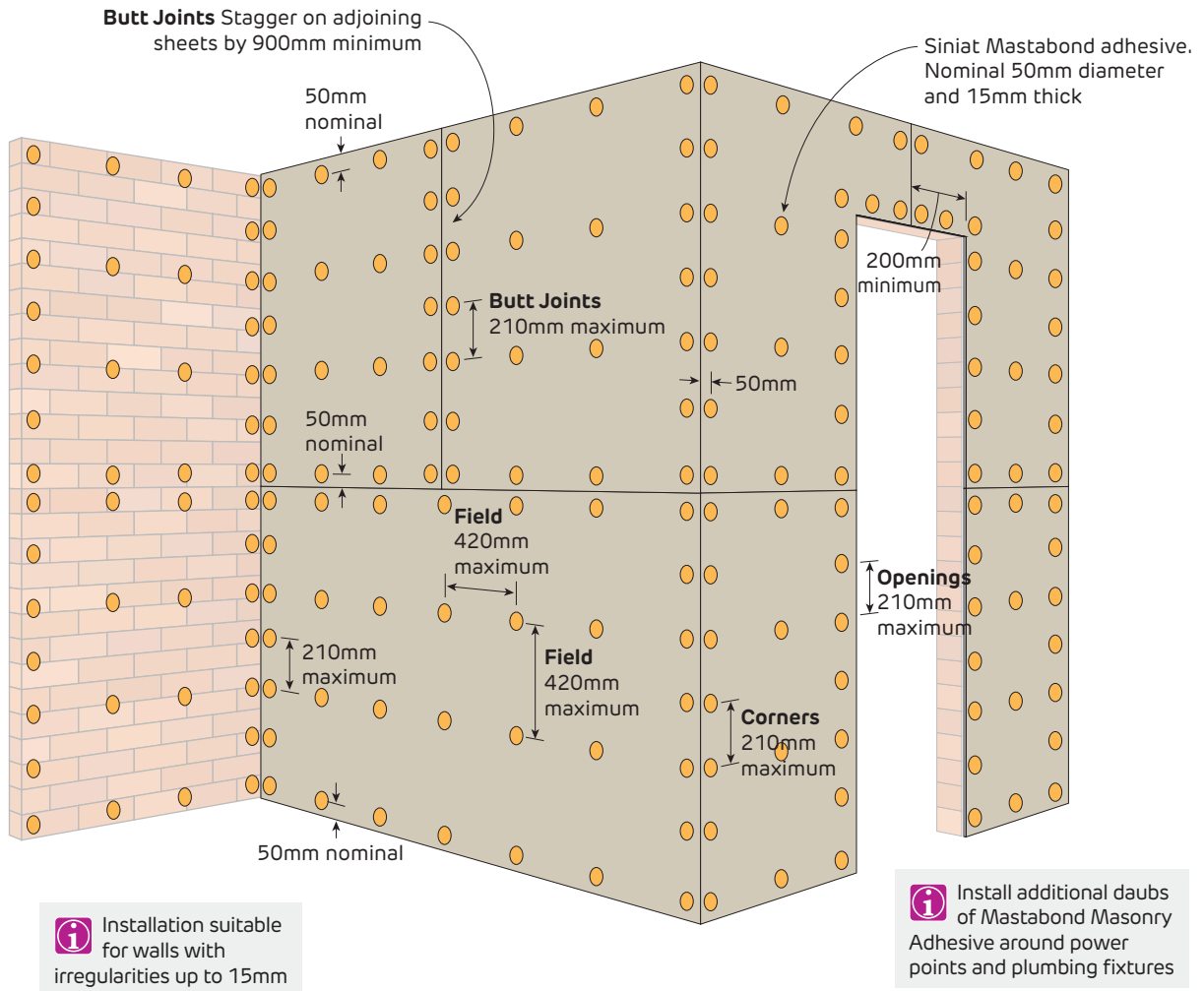

Fixing Pattern Table

Sheet Width	Fixing Pattern Across Width
600mm	M M M (3)
900mm	M M M (3)
1200mm	M M M M (4)
1350mm	M M M M (4)

M = Mastabond masonry adhesive daub

Maximum Wind Class Table

Plasterboard	Maximum Mastabond Spacing
	420mm
10mm Smartwall	N4

1. Wind loads in accordance with AS 4055 Wind loads for housing.
2. Calculated using rational engineering means with a safety reduction factor of $\Phi_b = 0.8$ for plasterboard bending, and $\Phi_c = 0.65$ for fixing point connections.
3. Calculations do not include the framing which must be independently designed to suit the desired wind zone.

i Do not use the Masonry Adhesive method for:

- > Masonry with a glazed surface finish
- > Fire rated systems
- > Multi-layer systems
- > Walls over three metres high
- > Pre-cast concrete panels that have a release agent on the surface reducing the effectiveness of the adhesive
- > Walls where the surface deviation is above 15mm
- > Walls that may become damp during service.

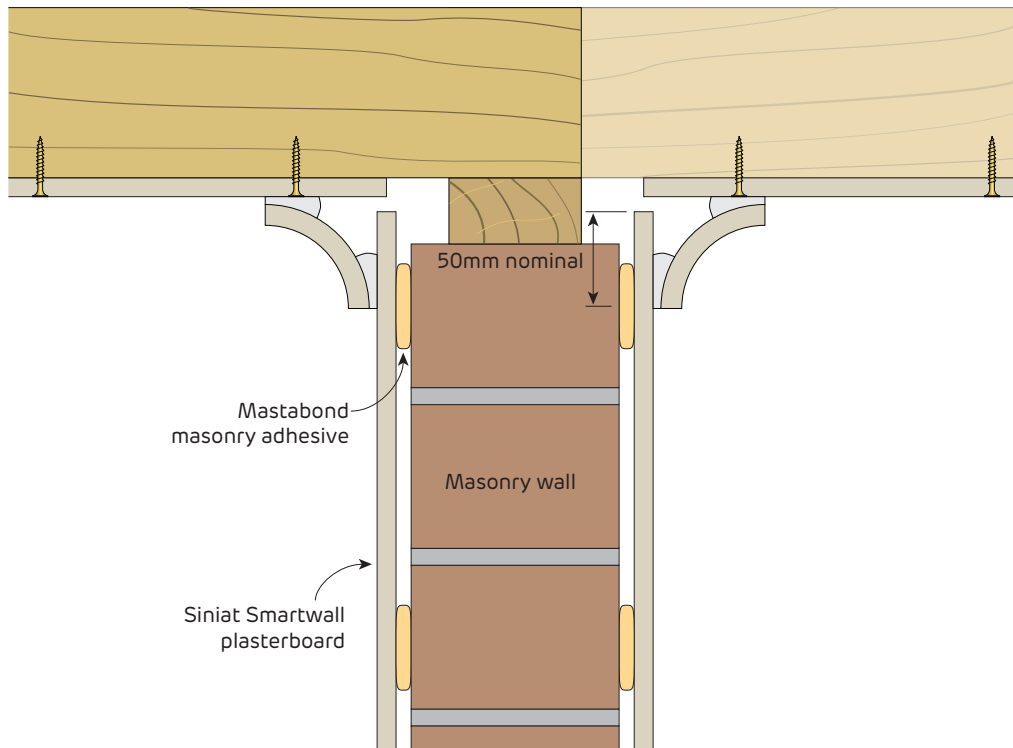
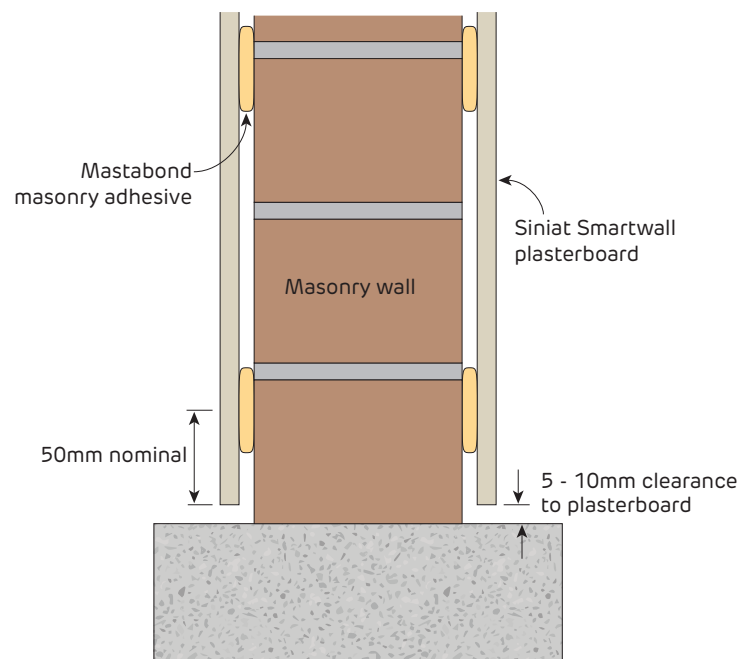
Internal Walls**FIGURE 4 Wall Head**
Section**FIGURE 5 Wall Base**
Section

Internal Walls

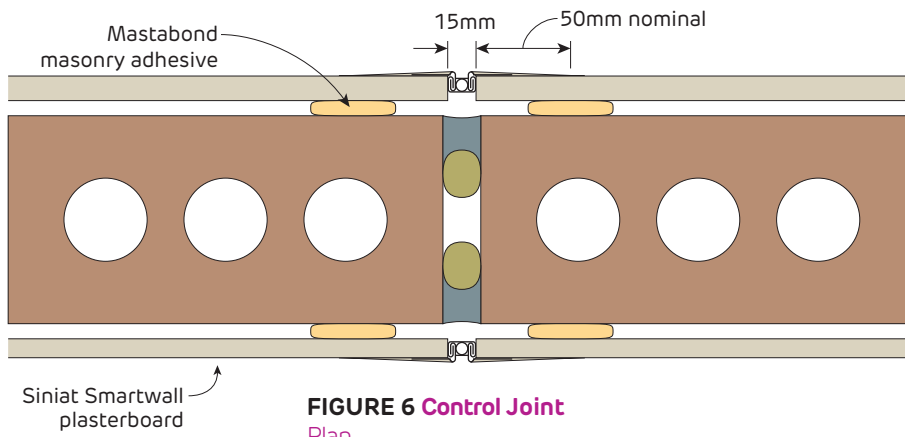

FIGURE 6 Control Joint
Plan

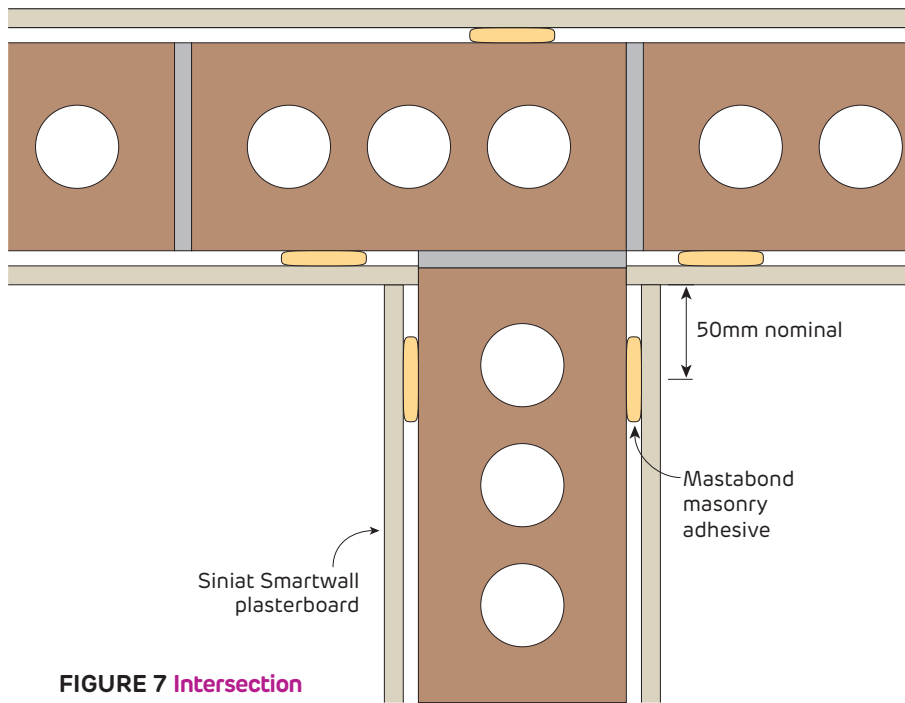

FIGURE 7 Intersection
Plan

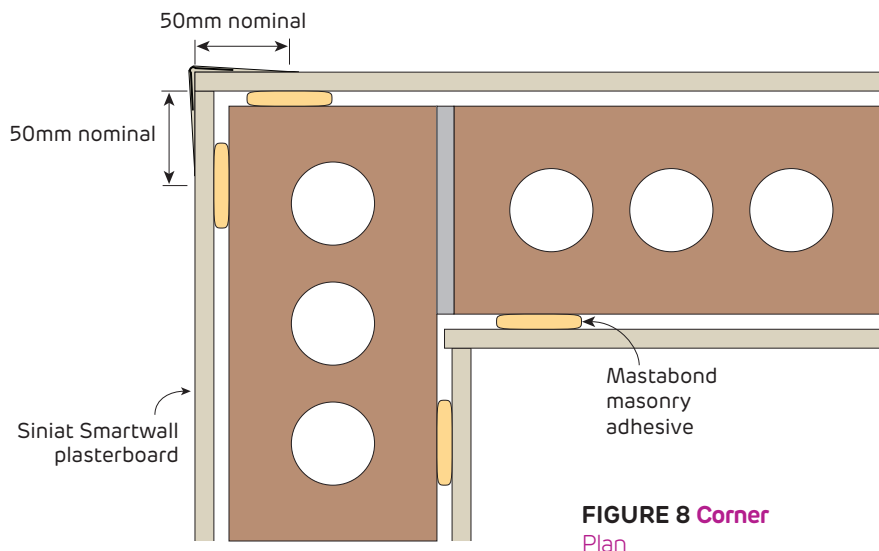

FIGURE 8 Corner
Plan



Window and Door Openings

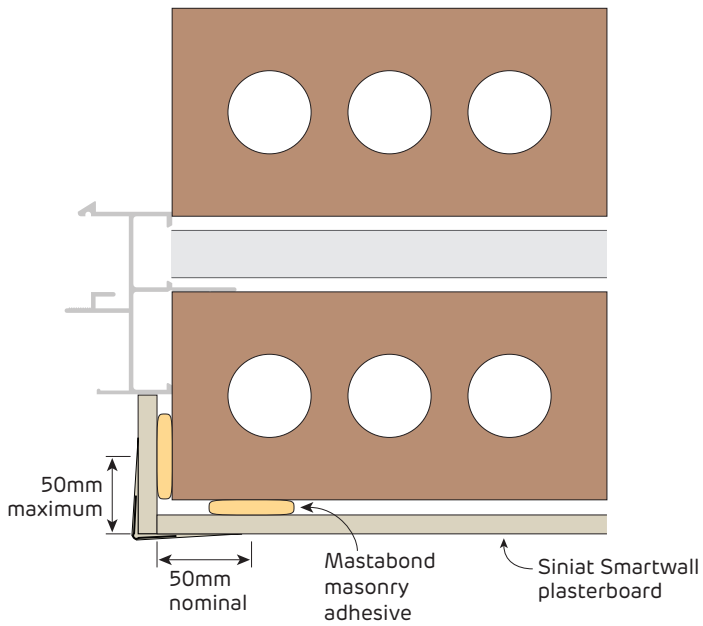

FIGURE 9 Typical Window Reveal
Double Brick - Plan

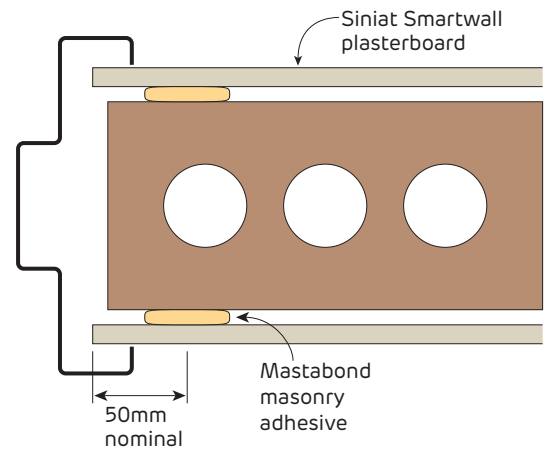

FIGURE 10 Typical Door Jamb
Single Brick - Plan



3.2 Wet Areas

Wet Areas Using Plasterboard

Australian Standard AS 3740:2021 – Waterproofing of domestic wet areas defines a wet area as 'an area within a building supplied with water from a water supply system and includes bathrooms, showers, laundries and sanitary compartments.'

Specifically designed to suit Western Australia, **watershield** can be installed over masonry walls in wet areas using **mastabond** masonry adhesive.

watershield joints in tiled areas are then set with either **mastabase** or **mastalongset** as shown and where required by *Australia Standard AS 3740:2021*,

Waterproofing of domestic wet areas, a liquid applied waterproof membrane is then used to provide the waterproofing layer.

Finishing and all-purpose jointing compounds such as **mastalite**, **mastaline**, **box ready mastaline**, **mastatape-in**, **mastacoat3** or **mastaglide** must not be used under tiles.

Joints outside of tiled area are finished as per normal, with a bedding coat, second coat and finishing coat of plaster jointing compounds.

For more information regarding wet area installation, please refer to the Siniat '**Plasterboard Installation Guide**' available from the Siniat website.

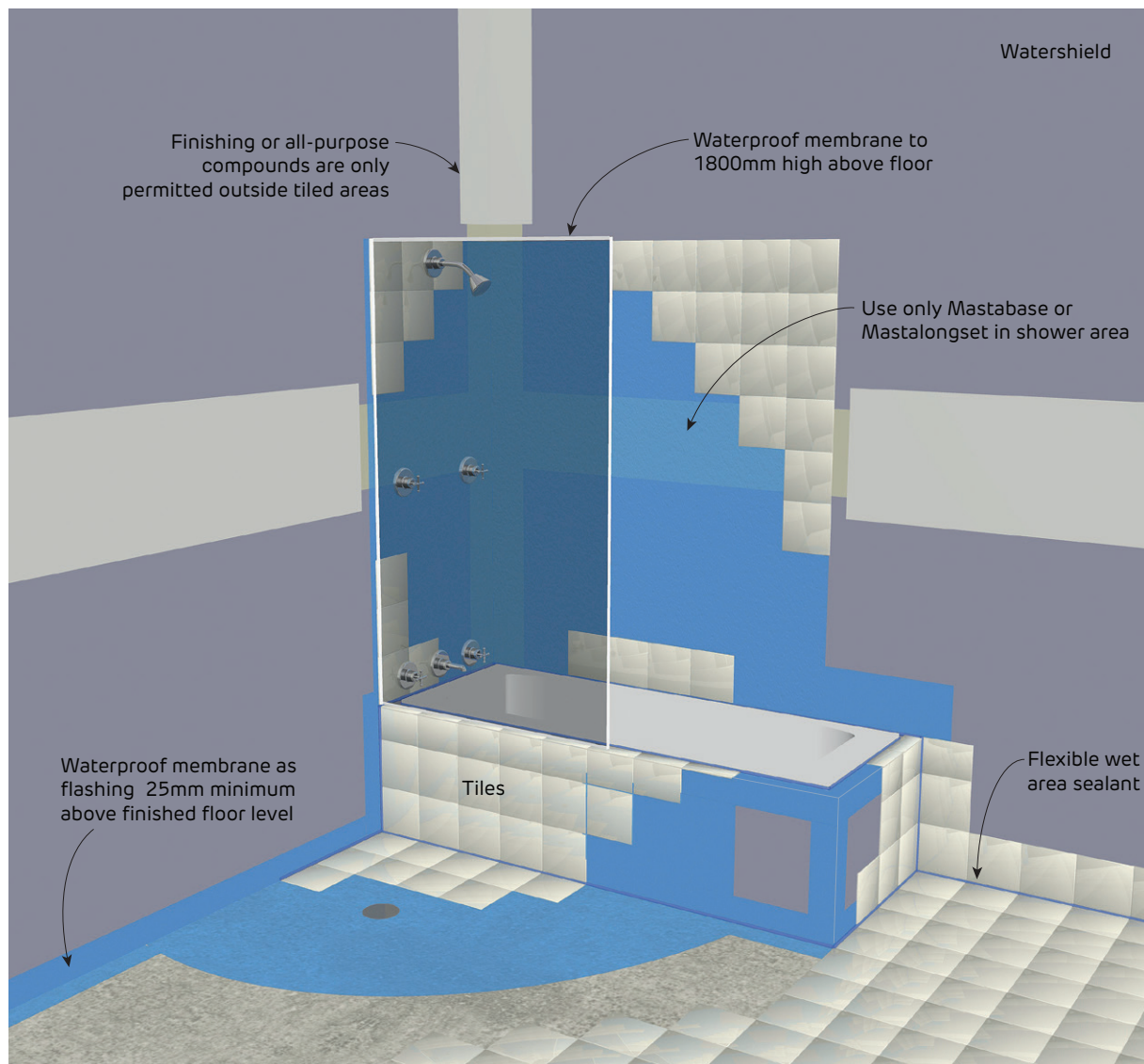

FIGURE 11 Bath with Shower over concrete floor



General Requirements

Waterproof all cut edges of **watershield** that may be affected by moisture, including all penetrations and the bottom edge over a preformed shower base.

Only use paper tape and **mastabase** or **mastalongset** for jointing in tiled areas to strengthen the joint and provide a continuous surface for the waterproof membrane.

Recess pre-formed shower bases, baths and spas sufficiently into the wall to allow the tiles to pass down the inside perimeter rebate of the shower base.

After the installation of tiles, apply a waterproof sealant to all wall/floor junctions and vertical corner joints.

Plasterboard Fixing

Refer to 'Plasterboard Fixing' in Section 3.1 for the installation of **watershield** in untiled areas.

Tiles weighing up to 32 kg/m² may be installed when **mastabond** masonry adhesive daubs are applied at intervals as shown in Figure 12.

Install additional **mastabond** masonry adhesive daubs near plumbing penetrations.



FIGURE 12 Watershield in Tiled Areas - 1 Layer Horizontal
Masonry Adhesive Method

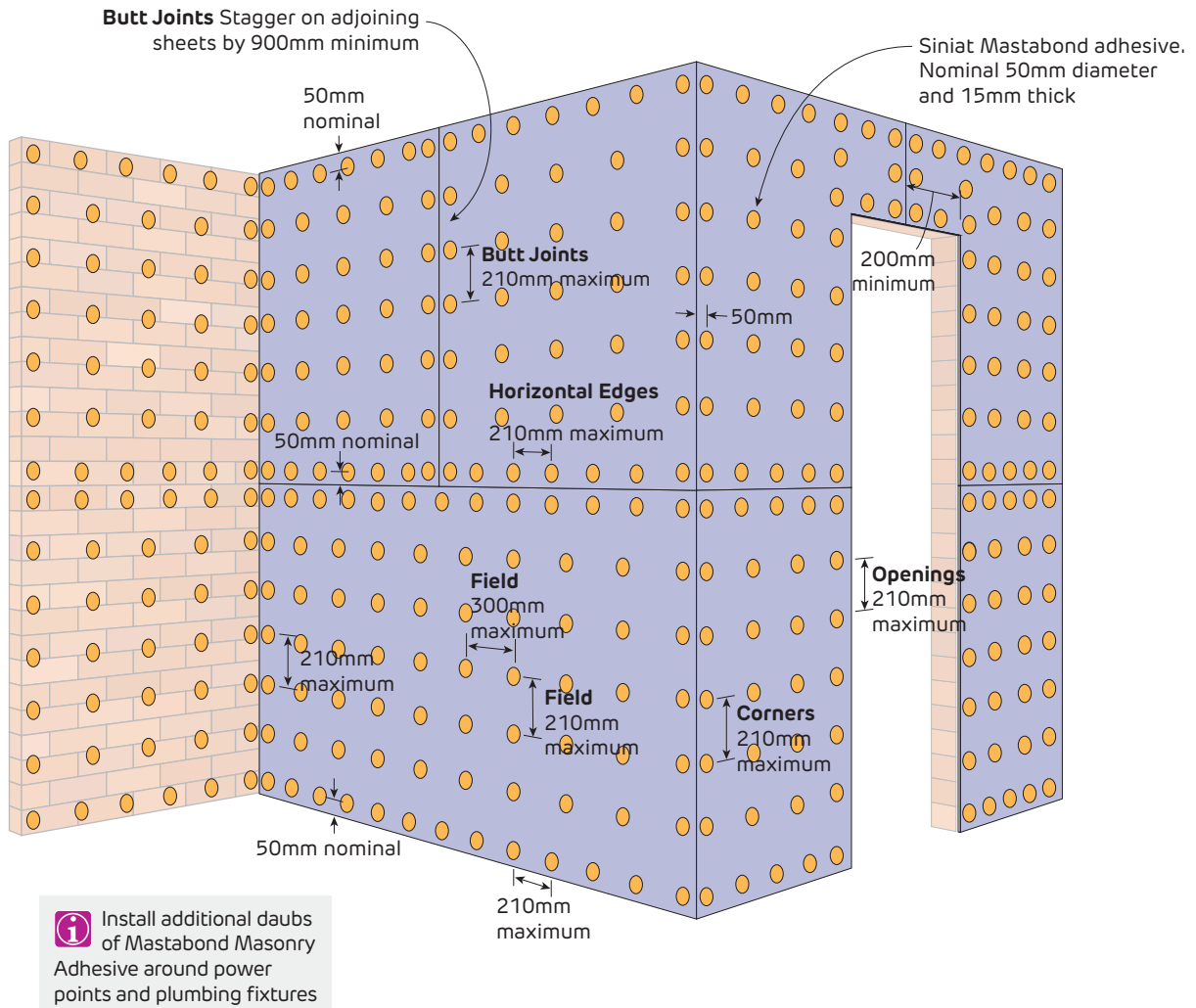

Fixing Pattern Table

Sheet Width	Fixing Pattern Across Width	Tile Weight
600mm	M M M M (4)	Maximum 32 kg/m ²
900mm	M M M M M (5)	
1200mm	M M M M M M M (7)	
1350mm	M M M M M M M (7)	

M = Mastabond masonry adhesive daub

Maximum Wind Class Table

Plasterboard	Maximum Mastabond Spacing
	300mm
10mm Watershield	N4

1. Wind loads in accordance with AS 4055 Wind loads for housing.
2. Calculated using rational engineering means with a safety reduction factor of $\Phi_b = 0.8$ for plasterboard bending, and $\Phi_c = 0.65$ for fixing point connections.
3. Calculations do not include the framing which must be independently designed to suit the desired wind zone.

i Do not use the Masonry Adhesive method for:

- > Masonry with a glazed surface finish
- > Fire rated systems
- > Multi-layer systems
- > Walls over three metres high
- > Pre-cast concrete panels that have a release agent on the surface reducing the effectiveness of the adhesive
- > Walls where the surface deviation is above 15mm
- > Walls that may become damp during service.

Wet Areas

i Refer to proprietary waterproof membrane manufacturer for specific application instructions.

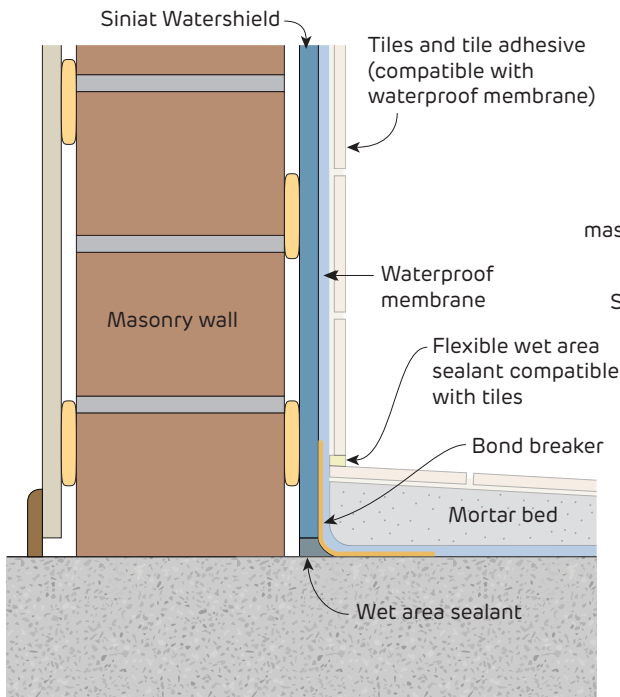

FIGURE 13 Shower over Masonry Wall
 Class 2 membrane shown - Section

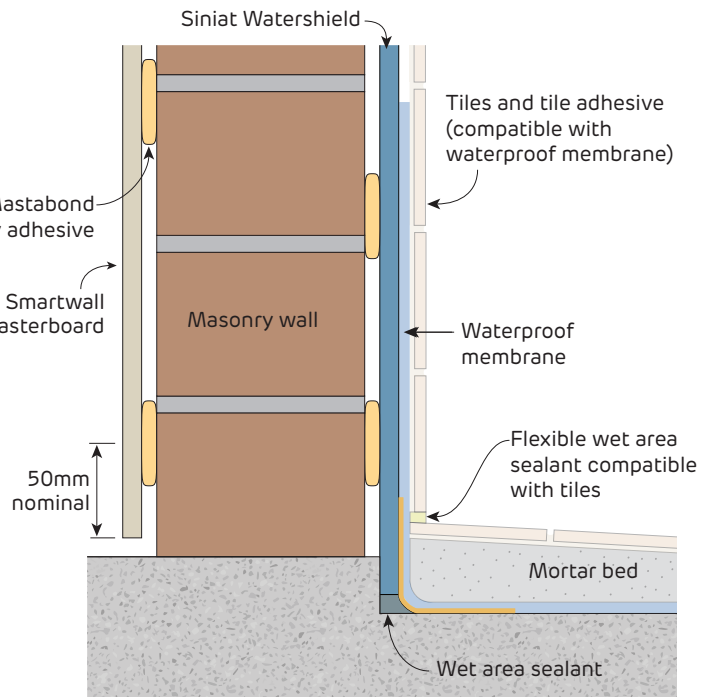

FIGURE 14 Shower with dropdown over Masonry Wall
 Class 2 membrane shown - Section

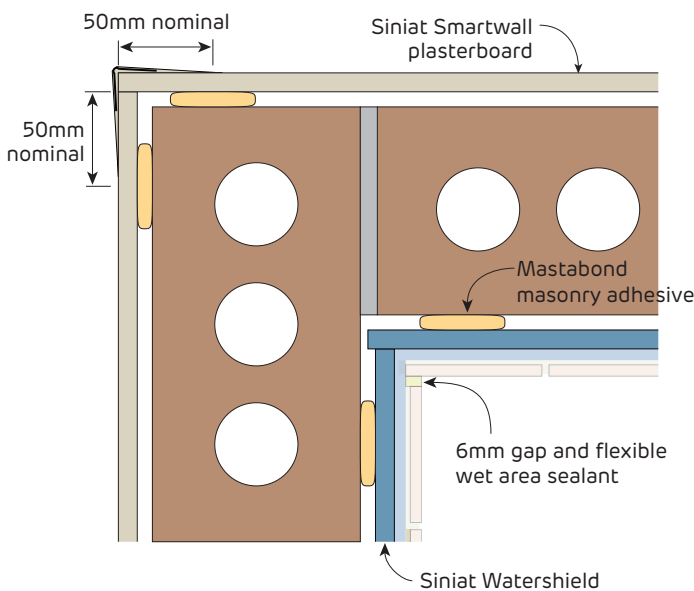

FIGURE 15 Shower Corner
 Plan

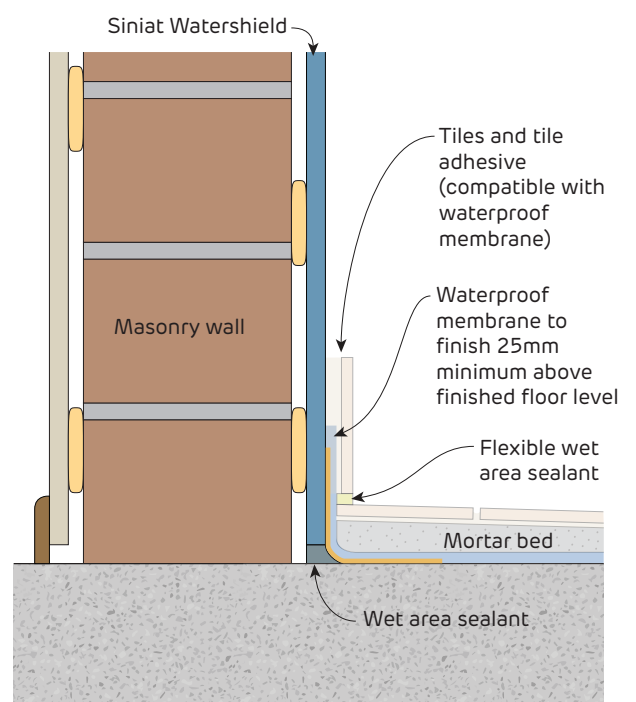

FIGURE 16 Wall Base in General Wet Area
 Outside shower - Class 2 membrane shown - Section



Etex Australia Pty Ltd
ABN 61 003 621 010

31 Military Road
Matraville NSW 2036

siniat.com.au



warranty

Siniat's products are guaranteed
by a 10 year warranty.
For details visit siniat.com.au

customer service and
technical advice

AU 1300 724 505